

AWARDS

2023
2022
2021
2020
2019

INTERIOR

Argo
Persol Co.
Office NO.7
Melal Credit Institution
Rona Tehran Office
Digikala
Sanofi Co.
Sefid restaurant
Nitel Pars.Co
Office Building NO.102
Phoenix Office Building
Mahtab Office Building
Meeting Room |Tara Market
Niko Lab
Rahyaft.Co
Fouman Chimie.Co
White Gym
Rona Shiraz Office
Arin
802 administrative unit
Aftab administrative unit

Arvinaj was founded in 2000 with main field of activity in furniture and accessories and with focus on office interiors, both as importer and manufacturer. Arvinaj tries to enhance the aesthetic design sensitivity of customers and concentrates on qualities of work space to define the practical principles of a contemporary Iranian design.

As one of pioneers in importing furniture, Arvinaj educated the visual taste of local interior designers and customers with modern style office interior design. The Group have worked as a media to introduce the forerunner international movements to the industry in local events and exhibitions. Today we can easily observe the effect of this approach in the furniture market.

In recent years Arvinaj was one of the most influential groups in the industry with attendance in numerous interior design projects as furniture supplier. The proficiency in production, flexibility in design and convenient material supplying experience have resulted in a successful career of interaction and teamwork with interior designers.

Arvinaj now have passed beyond limits and is seeking for brighter targets: Someday acting as “media” and narrating the foreign ideas and now is trying to be the “author” for Iranian design thinking.

Now Arvinaj is cooperating with HAMOUN , a group of contemporary designers, to enhance the skills, expand the field of activity and to redefine the meaning of interior design and furniture design.

Arvinaj

AWARDS AND HONORS

2023 | A'DESIGN AWARD | Silver Winner
| Hexa

2023 | A'DESIGN AWARD | Bronze Winner
| Ballerina

2023 | A'DESIGN AWARD | Bronze Winner
| Shahrokh

2023 | A'DESIGN AWARD | Iron Winner
| OO

2022 | A'DESIGN AWARD | Silver Winner
| Gis

2022 | A'DESIGN AWARD | Runner-Up
| Afra

2021 | The 9th National Contemporary Iran
Interior Design Award | Honored
| Asas Collection

2020 | The 8th National contemporary Iran
Interior Design Award | 1st Place In
The Furniture Category | Argo Lounge

2020 | The 8th National contemporary Iran
Interior Design Award | 3rd Place In
The Furniture Category | Shahrokh



AWARDS AND HONORS

✓ |2020| The 8th National Contemporary Iran Interior Design Award| 2nd place In The Concept Category| Dehliz Mansion



✓ |2019| The 7th National contemporary Iran Interior Design Award| The winner of Medal Of Honor| Konj -e- Hess

✓ |2019| Appreciated By The Mirmiran Foundation In The Article Category

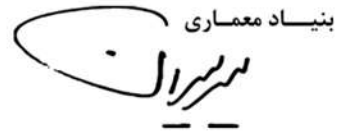

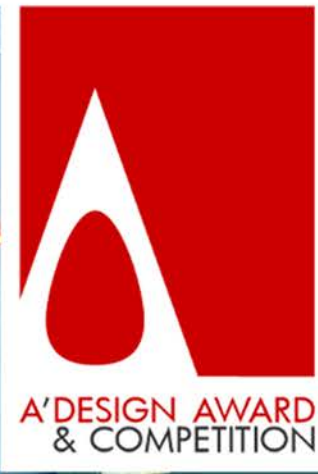

A'DESIGN AWARD
& COMPETITION

HEXA

Silver A' Design Award Winner
In Lighting Products and Fixtures Design Category

2022-2023



A'DESIGN AWARD
& COMPETITION

BALLERINA

Bronze A' Design Award Winner
in Office Furniture Design Category

2022|2023



A'DESIGN AWARD
& COMPETITION

SHAHROKH

Bronze A' Design Award Winner
in Furniture Design Category

2022|2023

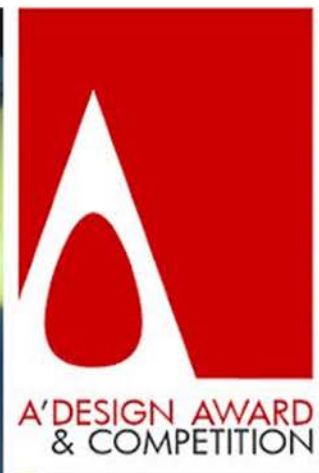

2022|2023

00

A' Design Award Winner
in Office Furniture Design Category



SILVER
WINNER

GLS

MAY|2022
A'DESIGNAWARD

RUNNER
-UP



AFRA

MAY|2022
A'DESIGNAWARD

HONOR

ASAS COLLECTION

IN THIS COLLECTION, THE DESIGNER IS TRYING TO ACHIEVE A KIND OF THINKING AND SKILL IN CREATING FURNITURE THAT NOT ONLY SOLVES A NEED, BUT ALSO CAUSES EXCITEMENT, COMPLETES THE SPACE AND CREATES A SPIRIT IN LIFE. MAN IS ALWAYS CONNECTED WITH ARCHITECTURE. MEANWHILE, THE FURNITURE IS THE NARRATOR OF THIS RELATIONSHIP THAT LEAVES A MEMORY OF THE BUILDING FOR THE HUMAN AND A MEMORY OF THE HUMAN FOR THE BUILDING. ASAS (FURNITURE) IS A HERITAGE OF MAN THAT SHOWS HIS PRESENCE OR HIS EMPTY PLACE IN ARCHITECTURE. FURNITURE LEADS THE CHARACTER OF THE BUILDING AND MAKES LIFE FLOW IN THE ARCHITECTURE. THE FOUR OBJECTS INTRODUCED IN THIS COLLECTION ARE PARTS OF THE HOPE OF ACHIEVING A GOAL. IN THE ESSENCE OF HIS THOUGHT, THE DESIGNER REDEFINES THE FURNITURE AND IN ALL THESE OBJECTS HE TRIES TO SHOW THE IMPRESSION OF THE FURNITURE ON THE SPACE.

DEC|2021
THE 9TH
NATIONAL
CONTEMPORARY
IRAN INTERIOR
DESIGN AWARD

1ST
PLACE IN THE
FURNITURE
CATEGORY

ARGO LOUNGE

DEC|2020
THE 8TH
NATIONAL
CONTEMPORARY
IRAN INTERIOR
DESIGN AWARD



3RD
PLACE IN THE
FURNITURE
CATEGORY

SHAHROKH

DEC|2020
THE 8TH
NATIONAL
CONTEMPORARY
IRAN INTERIOR
DESIGN AWARD

2ND
PLACE IN THE
CONCEPT
CATEGORY

DEHLIZ MANSION

DEC|2020
THE 8TH
NATIONAL
CONTEMPORARY
IRAN INTERIOR
DESIGN AWARD

HONOR

KONJ-F HESS

DEC|2019
THE 7TH
NATIONAL
CONTEMPORARY
IRAN INTERIOR
DESIGN AWARD

A' DESIGN AWARD & COMPETITION



Certificate of Excellence

this is to certify that

Sepehr Mehrdadfar

*has won the Silver A' Design Award
in Lighting Products and Fixtures Design Category
in 2022 - 2023 period with design #148179:
Hexa - Light.*

15 April 2023, Milan / Italy.

About The Silver A' Design Award

The Silver A' Design Award is a prestigious award given to top %5 percentile designs that have demonstrated an exemplary high level of excellence in design. Entries to the A' Design Award are judged by a grand jury panel that brings together World's leading professionals, prominent academics and influential press members. Ranking are based on blind peer-review process where entries are voted anonymously on pre-established evaluation criteria, with strict presentation guidelines and score normalization to remove biases. The ultimate aim of A' Design Award is to create a global awareness and appreciation for good design by featuring and promoting good design worldwide.



Alessandro Deserti
PRESIDENT
A' DESIGN AWARD & COMPETITION

Makpal Bayetova
VICE-PRESIDENT
A' DESIGN AWARD & COMPETITION

Onur Mustak Cobanli
COORDINATOR
A' DESIGN AWARD & COMPETITION

A' DESIGN AWARD & COMPETITION



Certificate of Excellence

this is to certify that

Sepehr Mehrdadfar

*has won the Bronze A' Design Award
in Office Furniture Design Category
in 2022 - 2023 period with design #141890:
Ballerina - Workstation.*

15 April 2023, Milan / Italy.

About The Bronze A' Design Award

The Bronze A' Design Award is a prestigious award given to top %10 percentile designs that have demonstrated an exemplary high level of excellence in design. Entries to the A' Design Award are judged by a grand jury panel that brings together World's leading professionals, prominent academics and influential press members. Ranking are based on blind peer-review process where entries are voted anonymously on pre-established evaluation criteria, with strict presentation guidelines and score normalization to remove biases. The ultimate aim of A' Design Award is to create a global awareness and appreciation for good design by featuring and promoting good design worldwide.



Alessandro Deserti
PRESIDENT
A' DESIGN AWARD & COMPETITION

Makpal Bayetova
VICE-PRESIDENT
A' DESIGN AWARD & COMPETITION

Onur Mustak Cobanli
COORDINATOR
A' DESIGN AWARD & COMPETITION

A' DESIGN AWARD & COMPETITION



Certificate of Excellence

this is to certify that

Sepehr Mehrdadfar

*has won the Bronze A' Design Award
in Furniture Design Category
in 2022 - 2023 period with design #148185:
Shahrokh - Chair.*

15 April 2023, Milan / Italy.

About The Bronze A' Design Award

The Bronze A' Design Award is a prestigious award given to top %10 percentile designs that have demonstrated an exemplary high level of excellence in design. Entries to the A' Design Award are judged by a grand jury panel that brings together World's leading professionals, prominent academics and influential press members. Ranking are based on blind peer-review process where entries are voted anonymously on pre-established evaluation criteria, with strict presentation guidelines and score normalization to remove biases. The ultimate aim of A' Design Award is to create a global awareness and appreciation for good design by featuring and promoting good design worldwide.



Alessandro Deserti
PRESIDENT
A' DESIGN AWARD & COMPETITION

Makpal Bayetova
VICE-PRESIDENT
A' DESIGN AWARD & COMPETITION

Onur Mustak Cobanli
COORDINATOR
A' DESIGN AWARD & COMPETITION

A' DESIGN AWARD & COMPETITION



Certificate of Excellence

this is to certify that

Sepehr Mehrdadfar

*has won the A' Design Award
in Office Furniture Design Category
in 2022 - 2023 period with design #148972:
Oo2 - Desk.*

15 April 2023, Milan / Italy.

About The Iron A' Design Award

The Iron A' Design Award is a prestigious award given to top %20 percentile designs that have demonstrated an exemplary high level of success in design. Entries to the A' Design Award are judged by a grand jury panel that brings together World's leading professionals, prominent academics and influential press members. Ranking are based on blind peer-review process where entries are voted anonymously on pre-established evaluation criteria, with strict presentation guidelines and score normalization to remove biases. The ultimate aim of A' Design Award is to create a global awareness and appreciation for good design by featuring and promoting good design worldwide.



Alessandro Deserti
PRESIDENT
A' DESIGN AWARD & COMPETITION

Makpal Bayetova
VICE-PRESIDENT
A' DESIGN AWARD & COMPETITION

Onur Mustak Cobanli
COORDINATOR
A' DESIGN AWARD & COMPETITION

A' DESIGN AWARD & COMPETITION



Certificate of Excellence

this is to certify that

sepehr mehrdadfar

*has won the Silver A' Design Award
in Furniture Design Category
in 2021 - 2022 period with design #105645:
Gis - Chair.*

15 April 2022, Milan / Italy.

About The Silver A' Design Award

The Silver A' Design Award is a prestigious award given to top %5 percentile designs that have demonstrated an exemplary high level of excellence in design. Entries to the A' Design Award are judged by a grand jury panel that brings together World's leading professionals, prominent academics and influential press members. Ranking are based on blind peer-review process where entries are voted anonymously on pre-established evaluation criteria, with strict presentation guidelines and score normalization to remove biases. The ultimate aim of A' Design Award is to create a global awareness and appreciation for good design by featuring and promoting good design worldwide.



Alessandro Deserti
PRESIDENT
A' DESIGN AWARD & COMPETITION

Makpal Bayetova
VICE-PRESIDENT
A' DESIGN AWARD & COMPETITION

Onur Mustak Cobanli
COORDINATOR
A' DESIGN AWARD & COMPETITION



Certificate of Achievement

this is to certify that

sepehr mehrdadfar

*has achieved runner-up status
in Furniture Design Category
in 2021 - 2022 period with design #140876:
Afra - Chair.*

15 April 2022, Milan / Italy.

About A' Design Award Runner-Up Status

The A' Design Award Runner-Up Status is a prestigious achievement given to top %30 percentile designs that have demonstrated an high level of success in design. Entries to the A' Design Award are judged by a grand jury panel that brings together World's leading professionals, prominent academics and influential press members. Ranking are based on blind peer-review process where entries are voted anonymously on pre-established evaluation criteria, with strict presentation guidelines and score normalization to remove biases. The ultimate aim of A' Design Award is to create a global awareness and appreciation for good design, by featuring excellent works such as this one.



Alessandro Deserti
PRESIDENT
A' DESIGN AWARD & COMPETITION

Makpal Bayetova
VICE-PRESIDENT
A' DESIGN AWARD & COMPETITION

Onur Mustak Cobanli
COORDINATOR
A' DESIGN AWARD & COMPETITION

ARGO LOUNGE

In the process of idea formation, the design thought was turned from interior architecture to object design that met needs.

- it should have specified the path.
- it had to keep the vision.
- It should not distort the structure of the building.
- It had to be compatible with the spirit of the space.
- It should have reflected the time.
- It had to create efficiency for the space.
- it had to defined the fields.
- It should cover parts.
- It should have been seen.
- it should have invited.
- it had to make memories.
- It should have created a familiar feeling.
- It should have remained like a building.

The result is a large counter placed in the middle, which has influenced the space with its curvature and shine.



In the southeast corner of the yard of Argo factory, there is a closed space with an area of 64 square meters with two entrance doors and three large windows. Brick grooves on the wall that were revealed due to the collapse of the original cover and show the old age of the building. Also, the brick flooring of this space places the viewer's eye along the main courtyard. The designer faced a necessity in creating the desired efficiency for a space with these specifications. In the Argo building, the body of the building was so important in terms of identity that interference in the architectural body had to be minimized. Also, the building appeared as an inescapable principle and actually interpreted the characteristics of the upcoming idea. In other words, the idea should have been formed in such a way that, at the same time, it did not harm the architecture (the spirit of the space) and the building (the body of the space), but also took two steps in line with its personality.



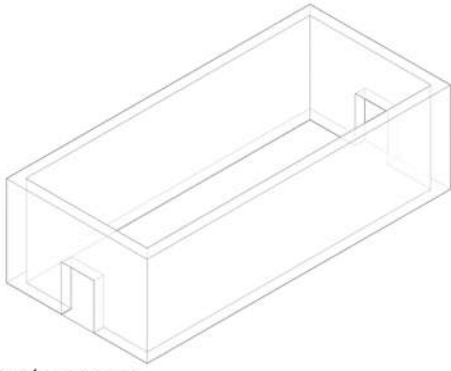

1. Empty space

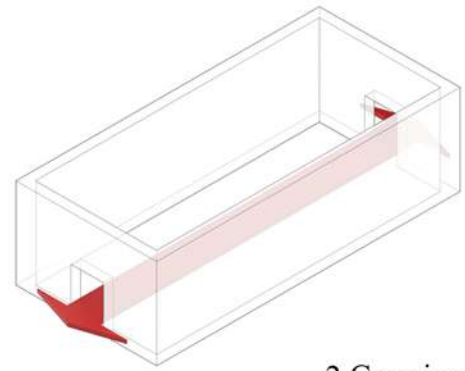

2. Crossing line

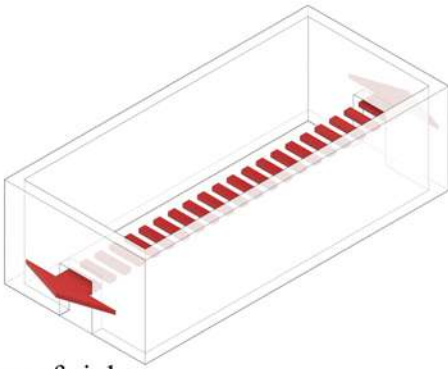

3. Line of sight

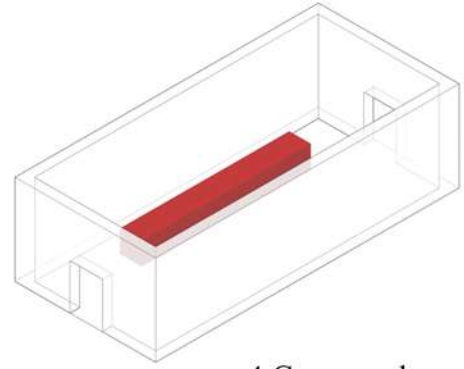

4. Counter placement

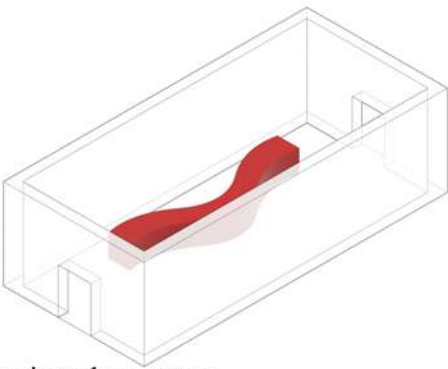

5. Moving the center of the form outward to accommodate the coffee machine and emphasizing the placement of the beer keg

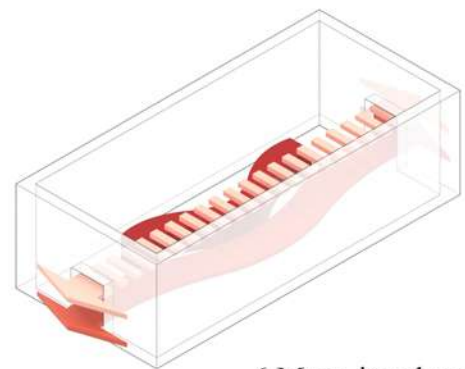

6. More involvement of the counter form with the perspective of the audience and change behavior in passing

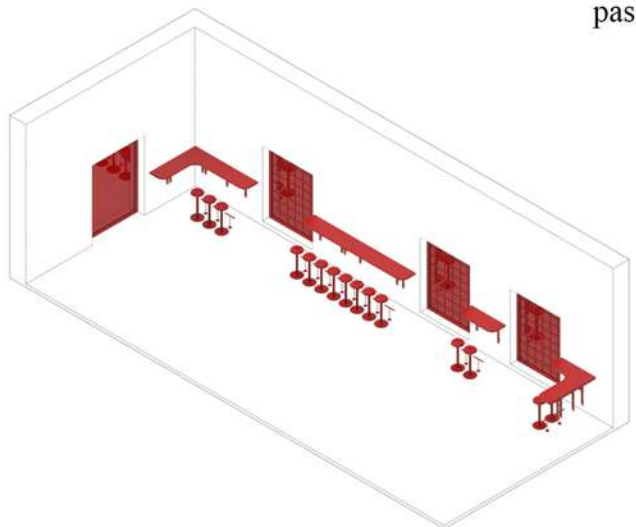
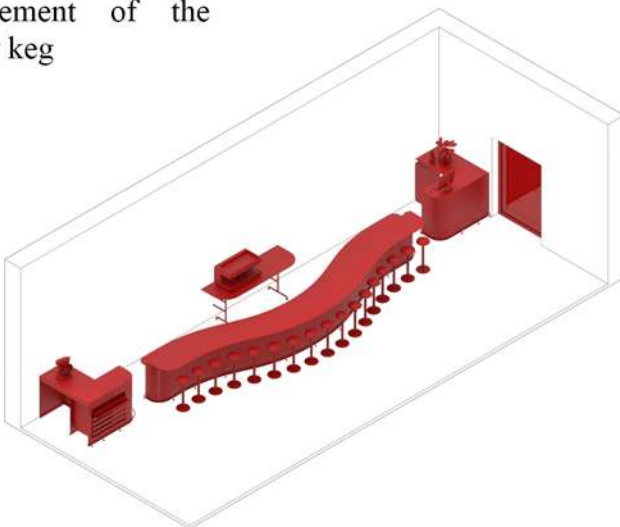

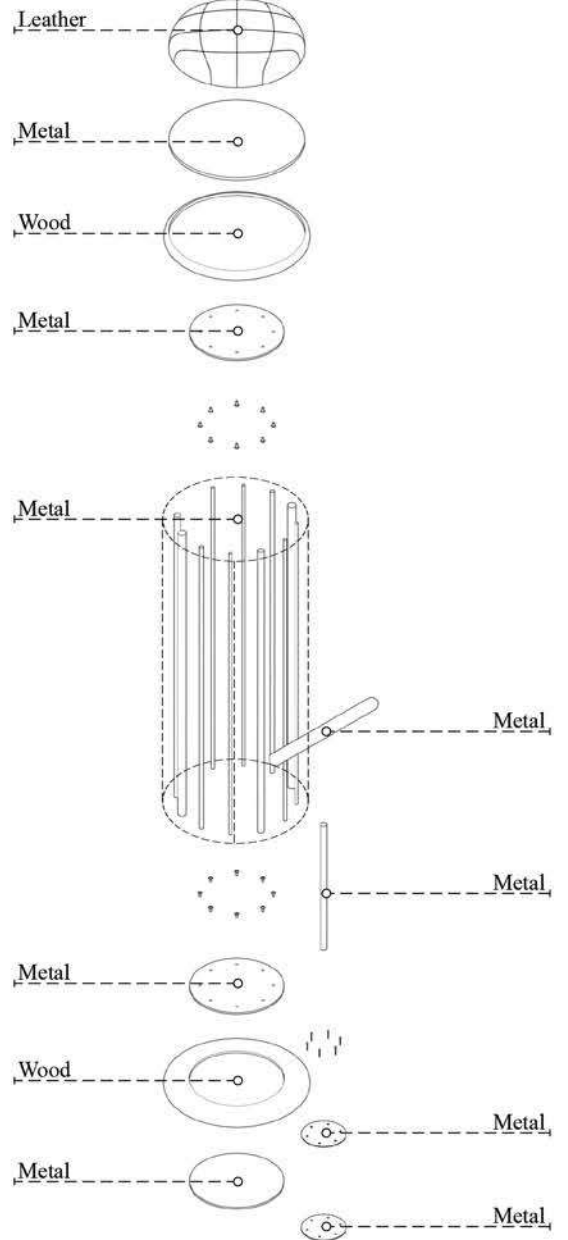
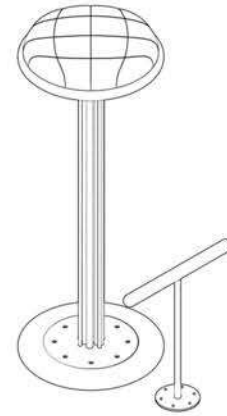



PERSOL COMPANY

An office space with an area of 340 square meters was the subject of the design, which had to respond to various functions. According to the initial definition of the project, the functional fields were incongruent in some situations while they were adjacent and had common access. For example, the start-up group needed an open space to provide interaction between people, while next to them, silence and privacy were the basic needs of the financial group. Meanwhile, a space was needed for numerous internal and external meetings, and also a space had to be allocated for the operations of the commercial group, which, while similar to the needs of the financial group, had to be placed in direct interaction with the start-up space. In planning for privacy and adjacencies, it was considered that the financial group would be placed on the edge of the plan and in a closed space, while the central part of the plan was given to the start-up group in an open and interactive manner. A transparent glass cube was also placed near the reception area to act as a barrier between the entrance area and the startup area. In this transparent volume, two operational areas were placed. One is a meeting space and the other is a commercial space.

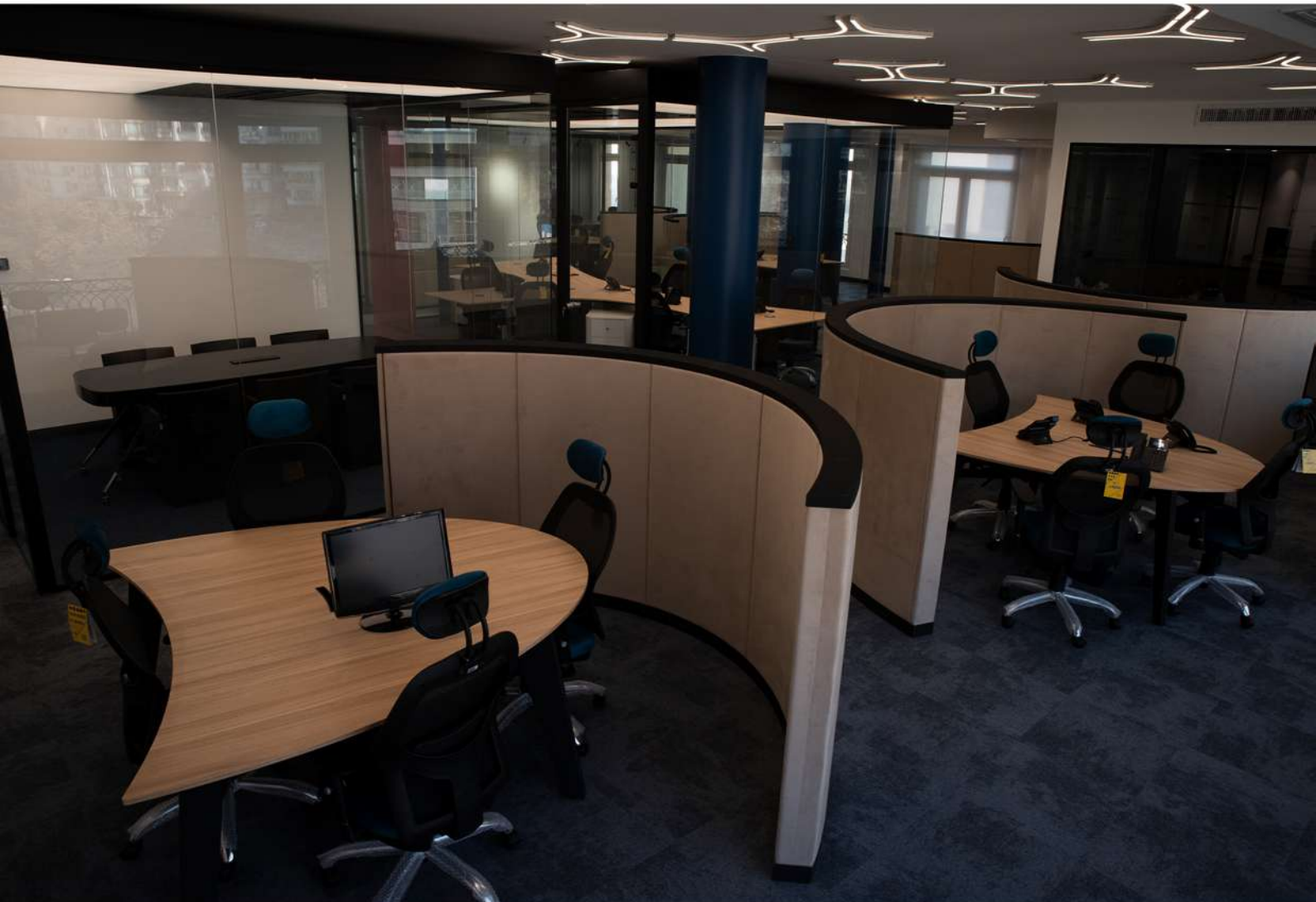

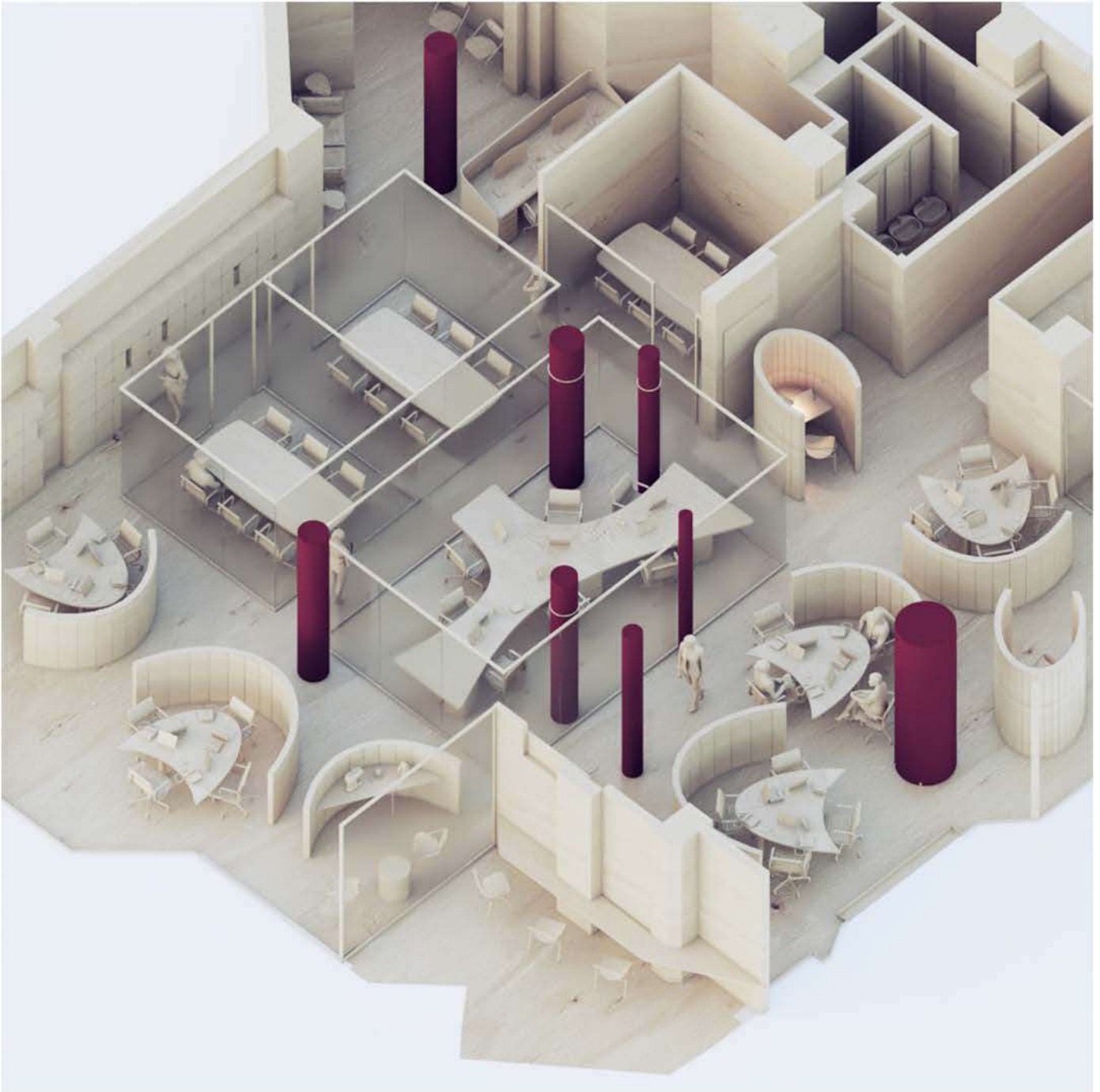



The remarkable point in the design of this space is the way to communicate and meet the needs of areas and functions through the design of furniture. Group work spaces were designed as separate departments, but in such a way that the integrity of the space is not disturbed. Each department consists of a group work desk that is defined by a fabric separator. The commercial space table is another example of furniture design to improve the use of space in this project. The lighting devices were chosen in a way to emphasize the visual separation of the glass cube from the working group space. A texture of linear lights (this lamp named Hexa was designed and presented by Hamoun Group) is placed in contrast with the integrated light of the cube to prove this claim.





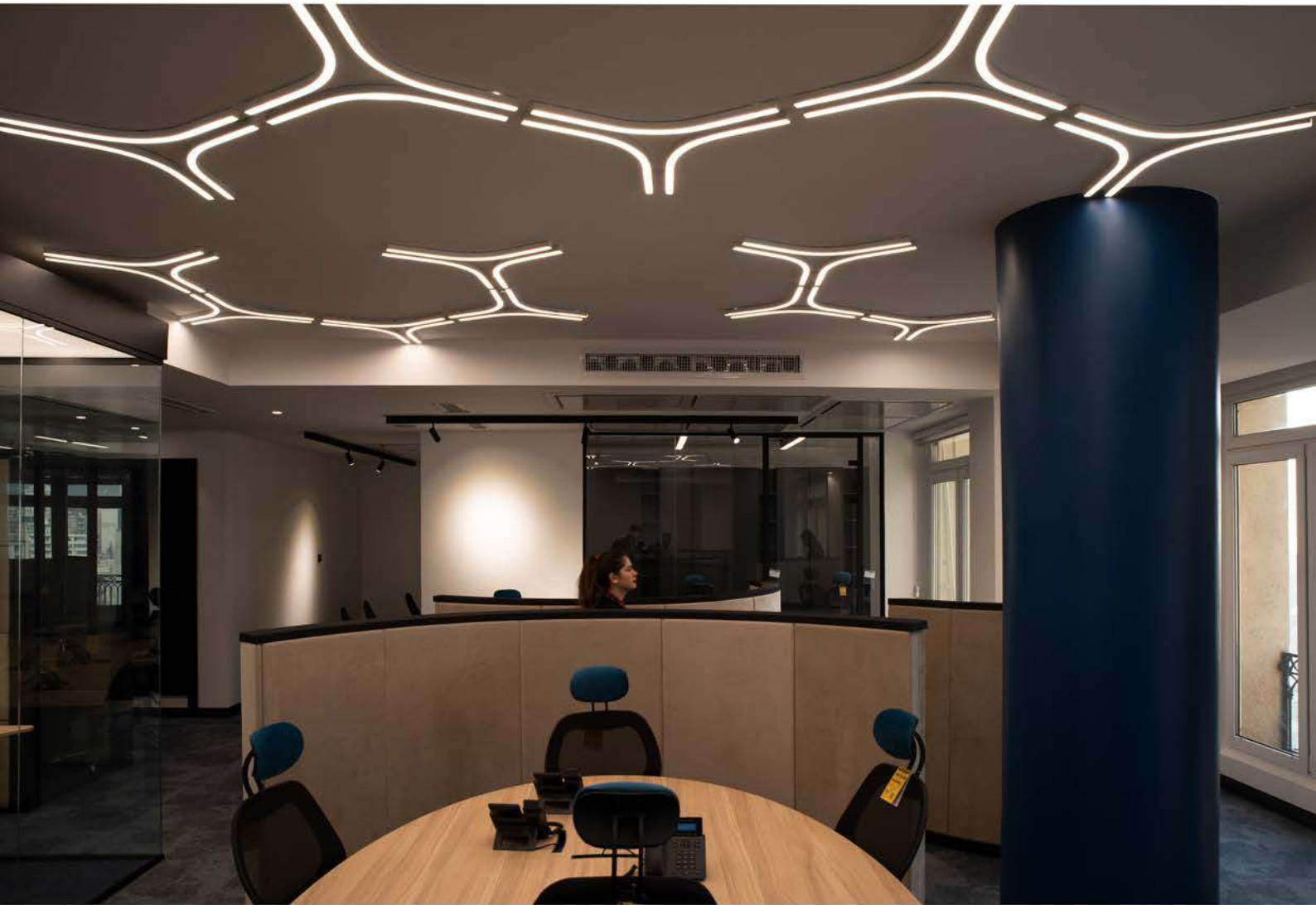

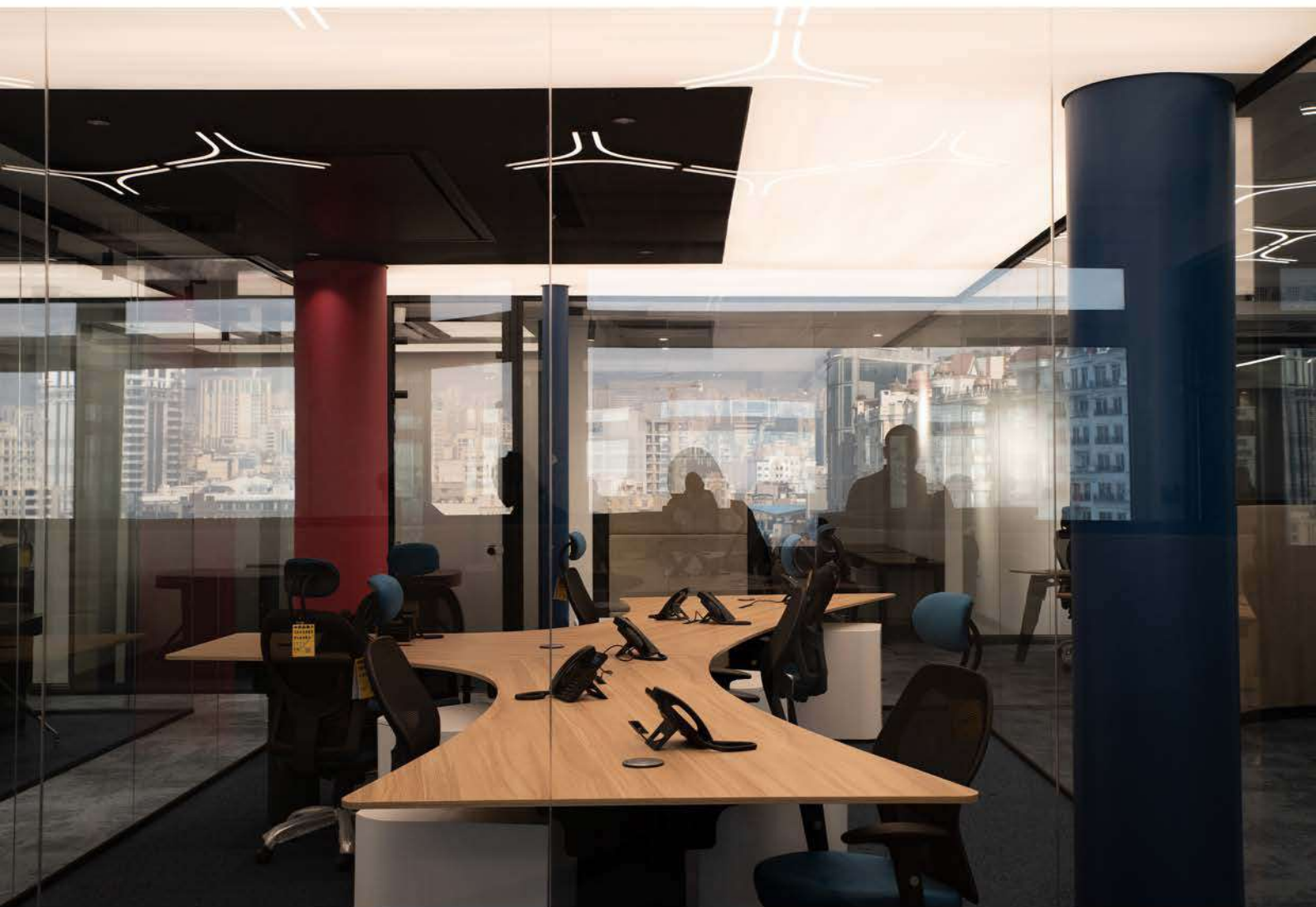





OFFICE NO.7

The main concept during design process was depicting the connection between “space” and “furniture”. The designers tried to demonstrate the correlation of this two parameters as two words: “impressed” and “impressive”, and present it as the heritage of relationship between “human” and “built-environment”.

Consequently, the design team were to minimize manipulation in the “body” of building and concentrate on the effect of furniture on space. Therefore, the space attained a unique and unrepeatably identity and reached the qualities of a “Place”.

In “the 7th Floor” project the act of interior design is not implemented as a usual routine and the designers tried to create a “Place” using objects. Each object defines an intuitive boundary around itself and the Place is signified as a collection of these harmonic objects.

“Furniture” flourishes the full potential of space and can be comprehended as a “hidden architecture”. It determines the “zones” and accentuates specific areas. Everything is happened by “furniture” in this space and without it the space becomes “futile”.

“Furniture” specifies the architectural space and prepared it for human presence. In other words, it domesticates the space for human activities and give him the opportunity to “be”. Therefore, it can be said that in architecture discipline the “furniture” is one of “existence” ingredients.







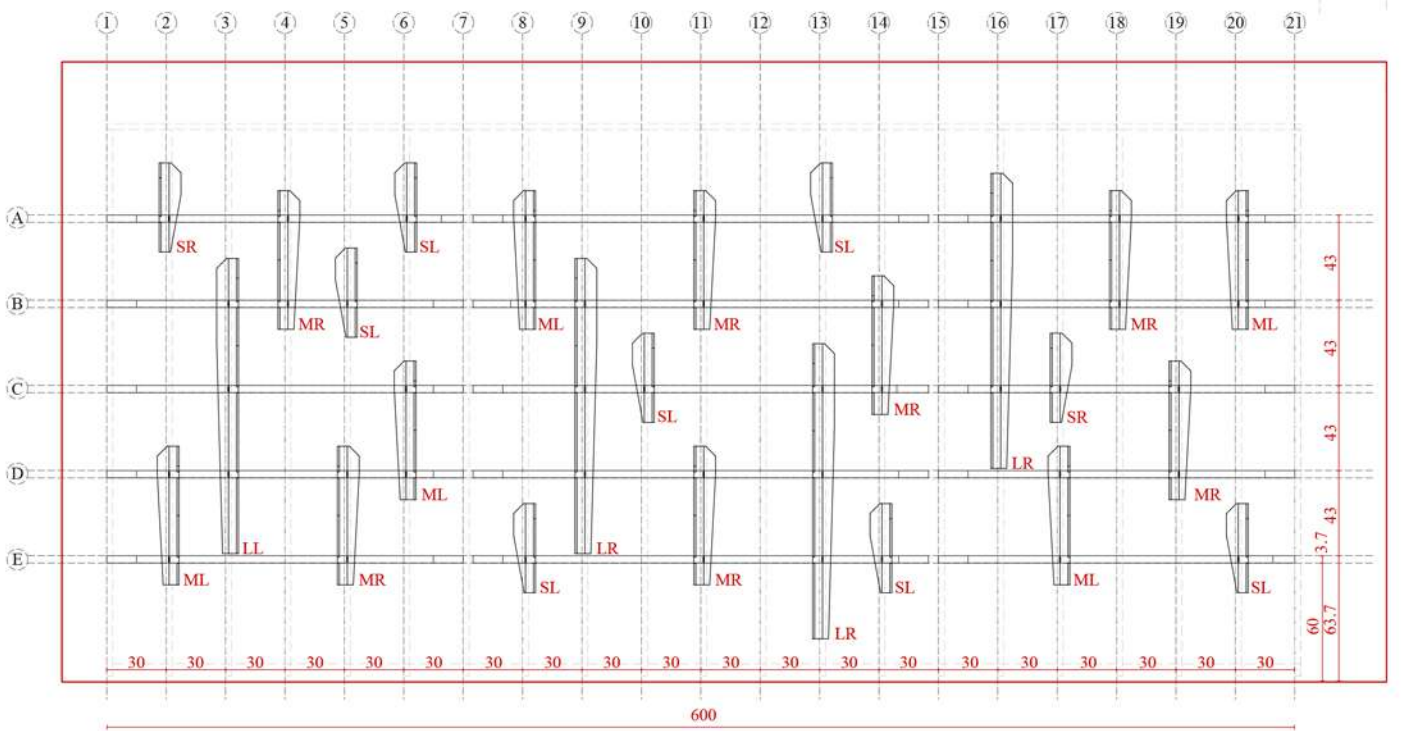
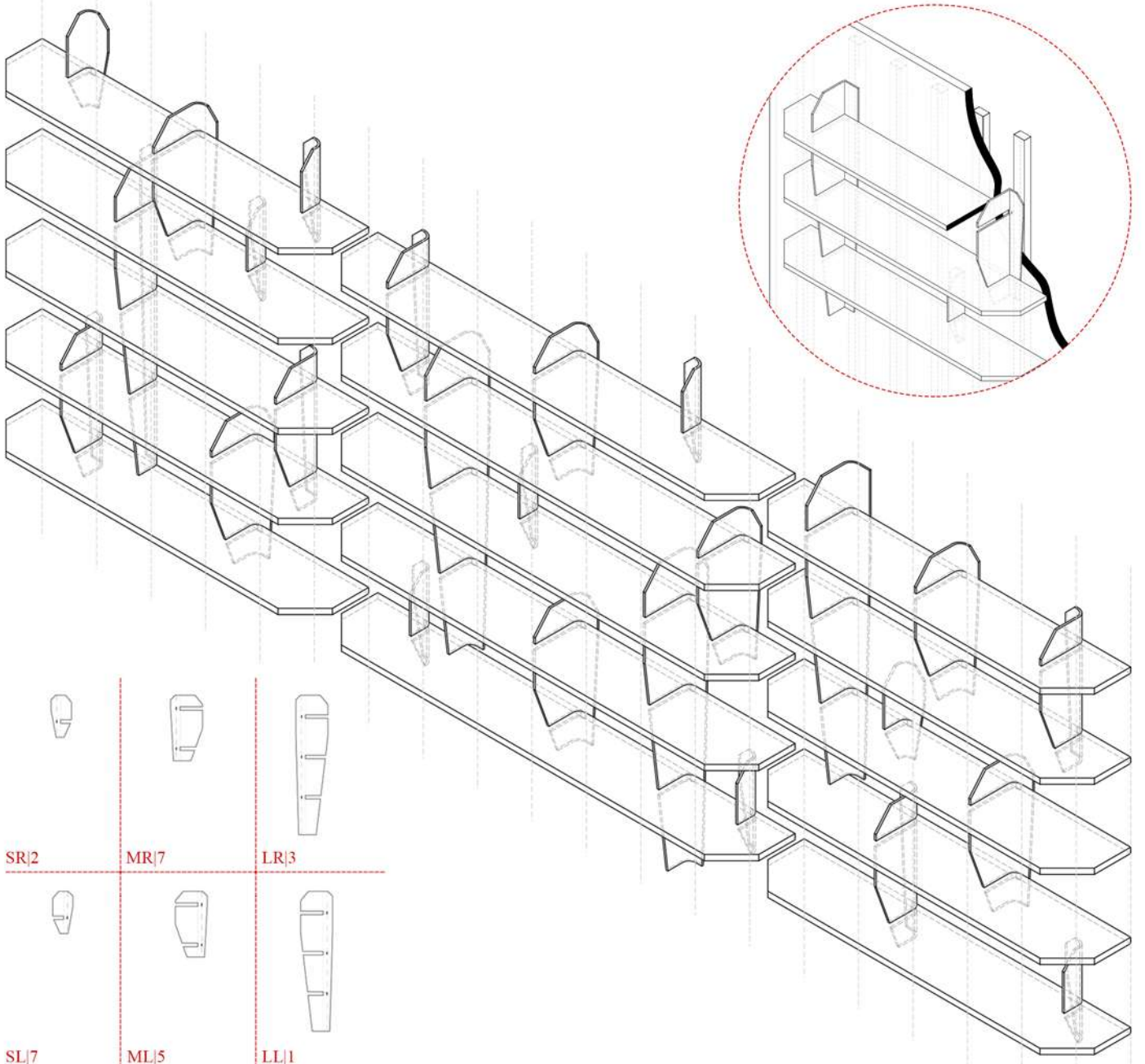

This library is designed as a multi-part. bent metal sheets are placed on the wall and hold wooden plates. This library is designed as separate parts and this allows the user to change the layout of the wooden plates. In ancient times, in Iranian houses, holes were created inside the plaster wall, which were used to store decorative items or books or other necessary items. The surface formed at the bottom of these holes on the walls was called " Taaqche " (niche).





MEAQ

/ Name of light

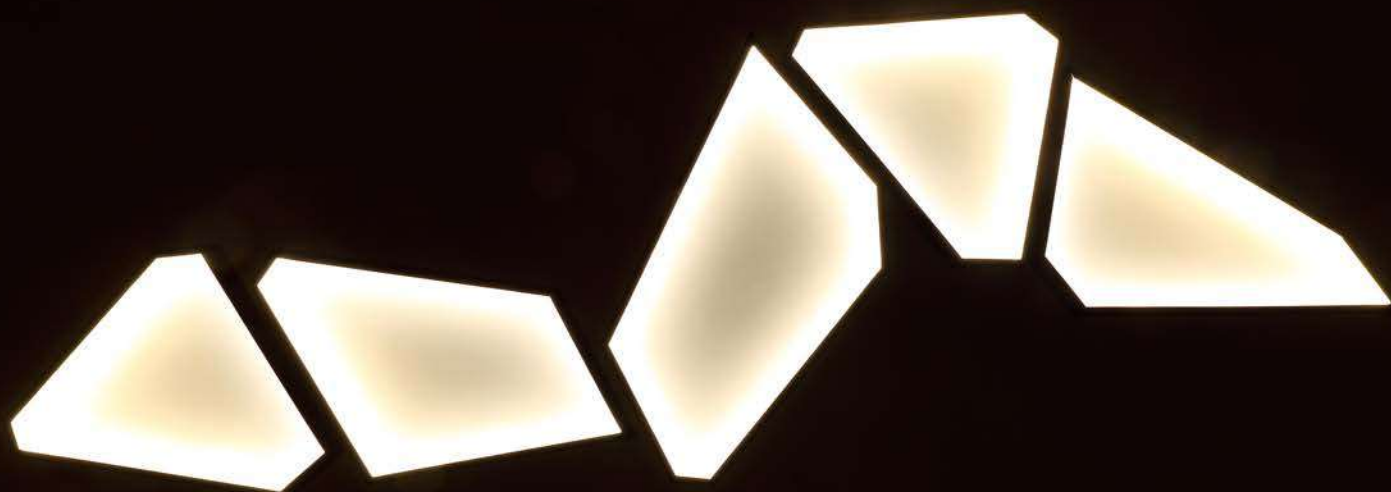



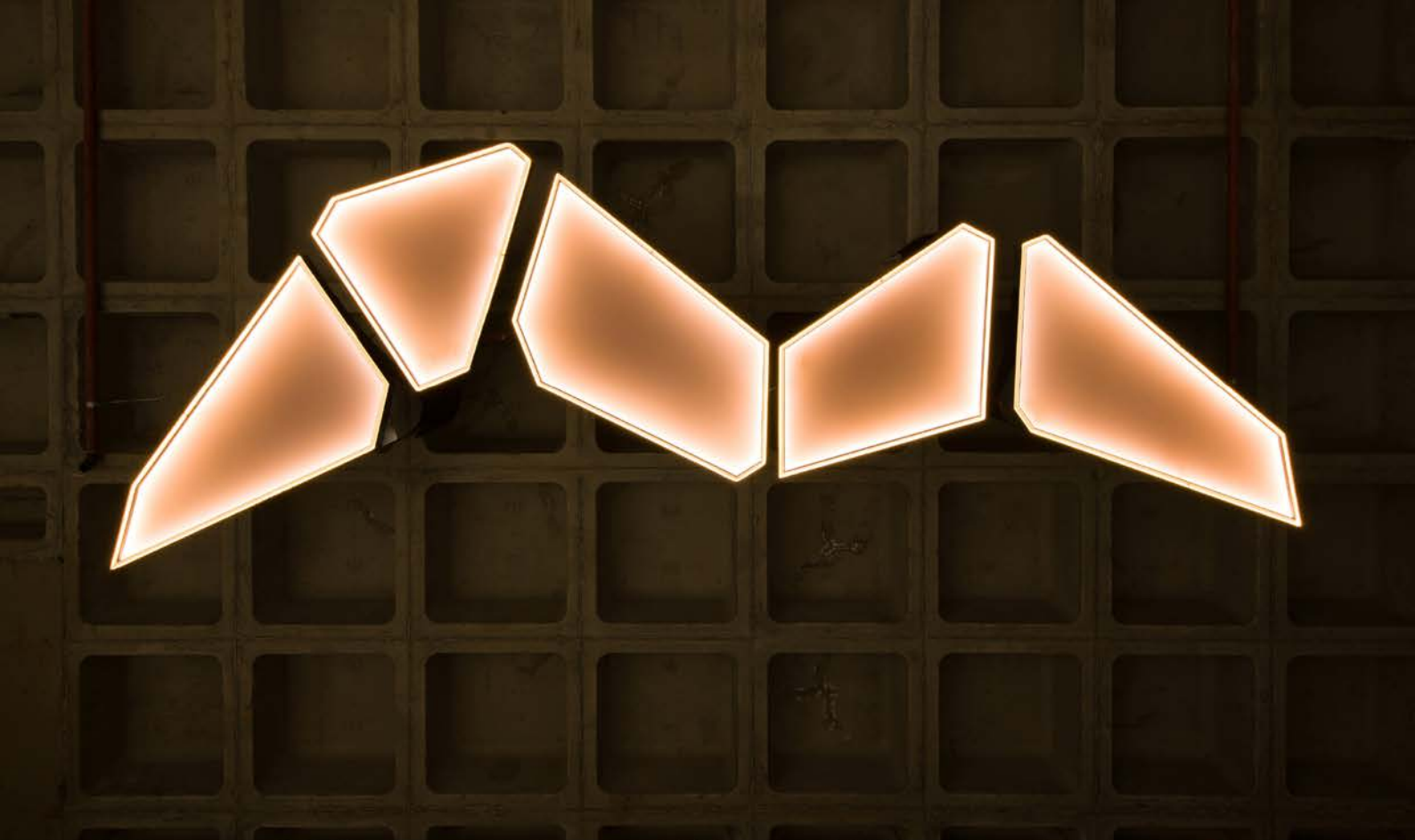





MELAL CREDIT INSTITUTION

FUNCTION: Official
CLIENT: Melal Group
LOCATION: Tehran, Iran
CONDITION: Concept Presented
AREA: 1500 M2
DATE: spring 2021

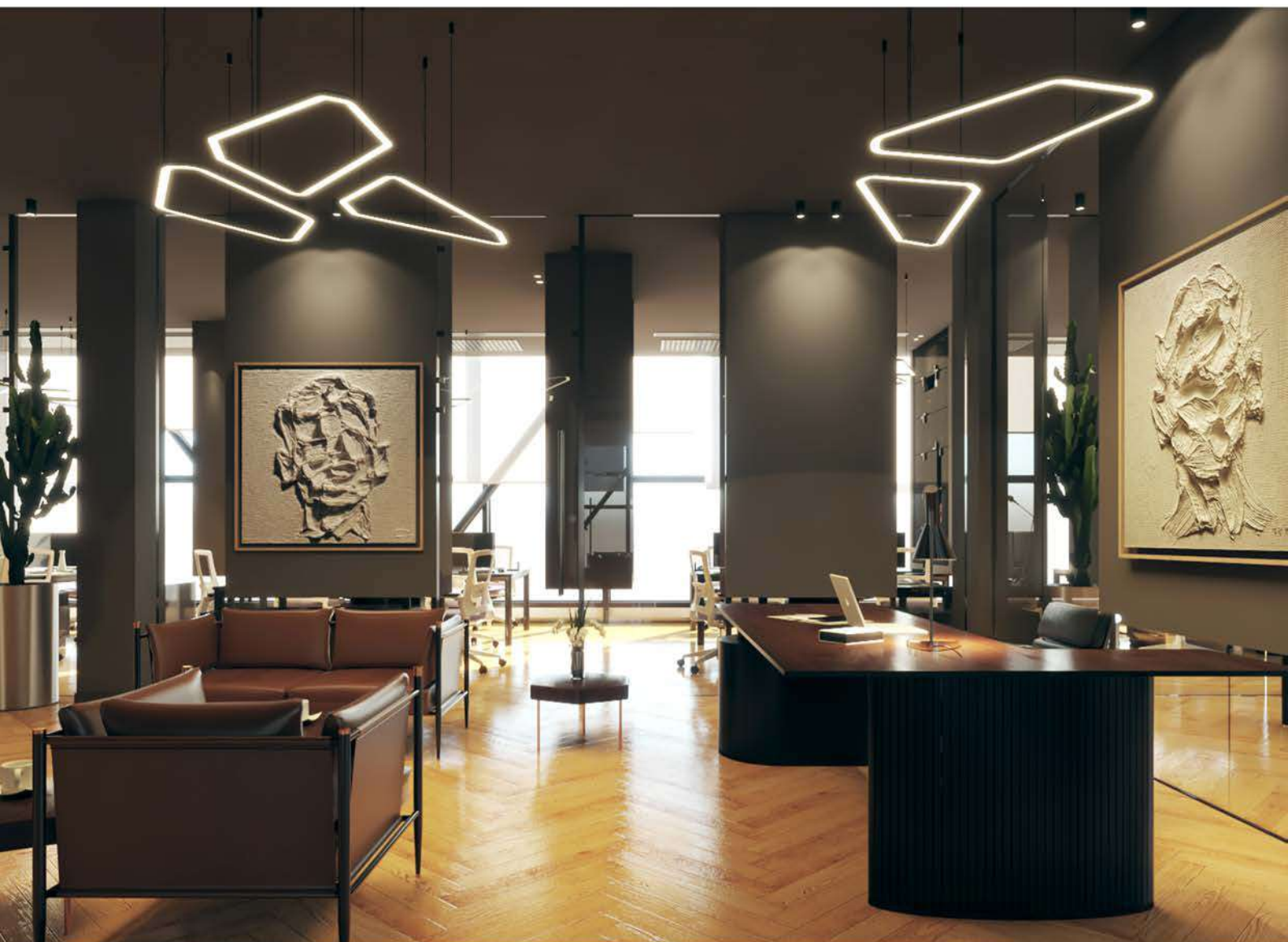

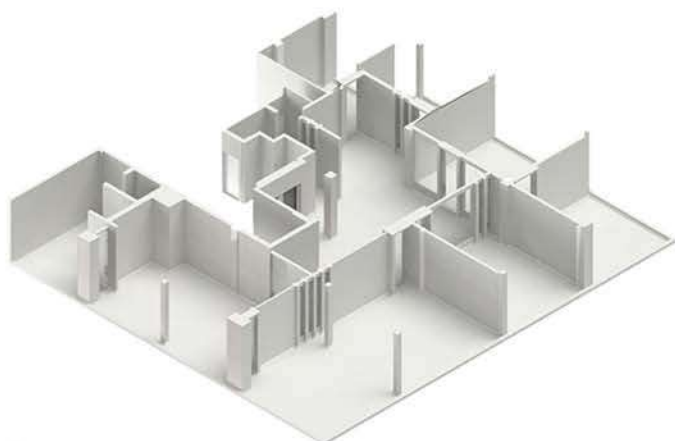

1

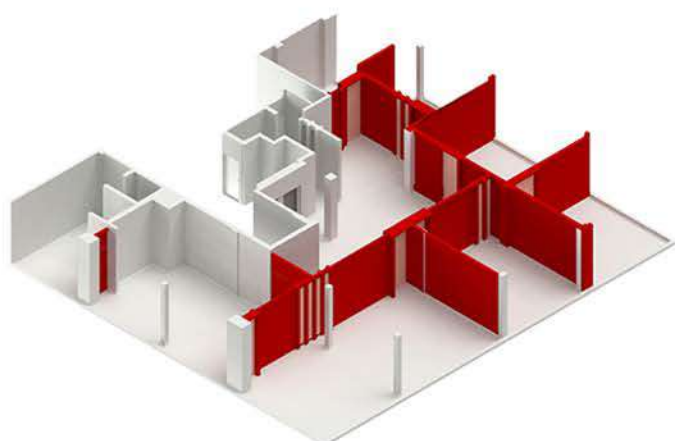

2

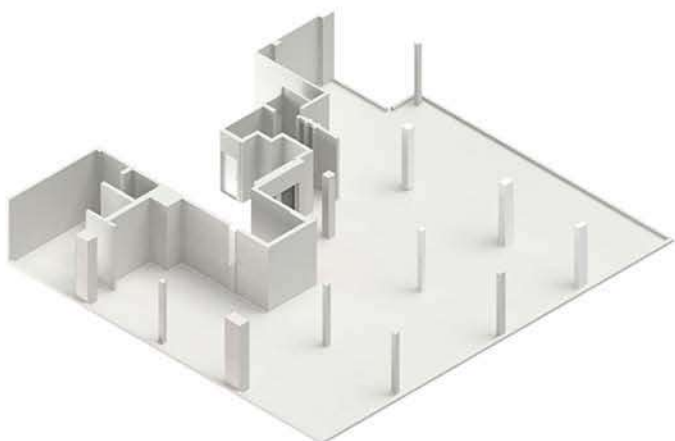

3

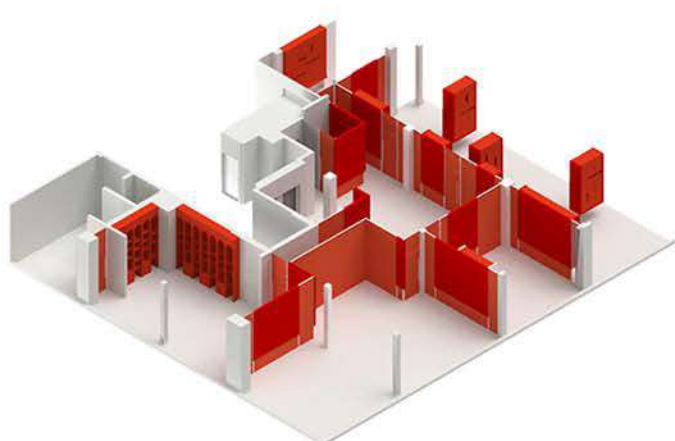

4

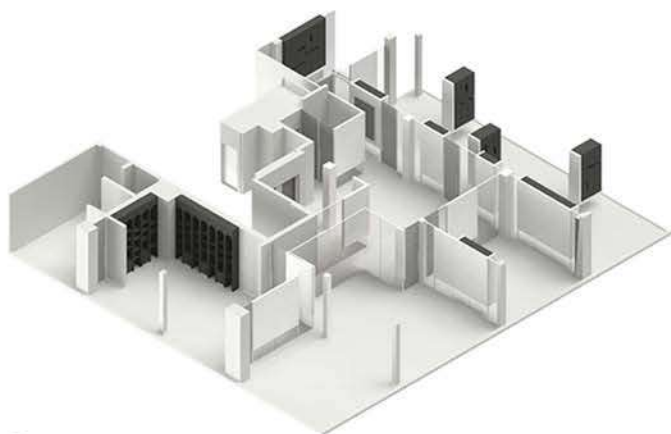

5





RONA LIGHTING GROUP CENTRAL OFFICE

Function: Official, show and sell products

LOCATION: Tehran, Iran.

CONDITION: built

AREA: 150 m²

DATE: Fall 2021

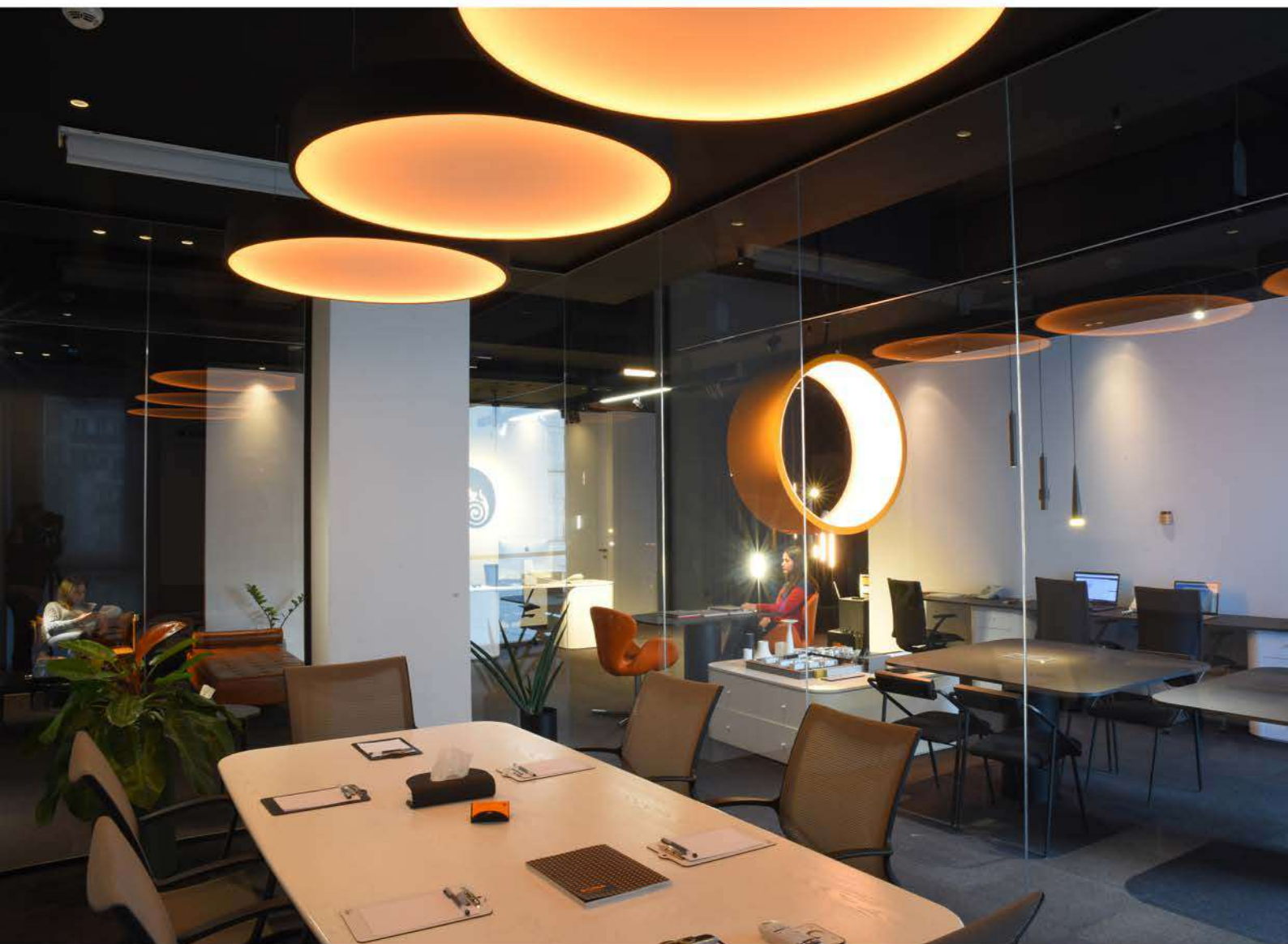



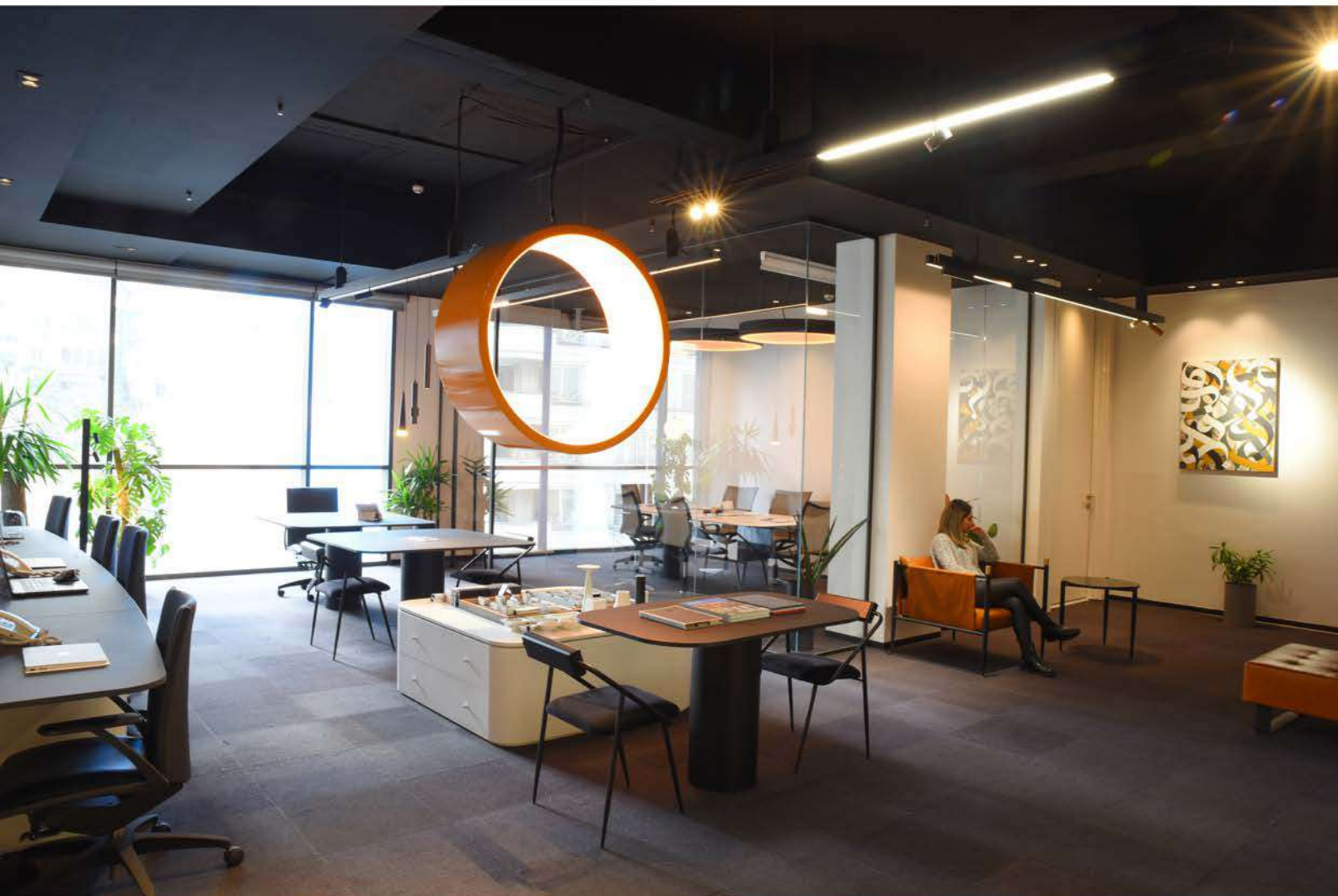

DIGIKALA OFFICE

This object is a floor chair designed for short rest in office spaces. A soft pile of foam with a linen fabric cover that is placed on the floor and a pod with a wooden structure and a foam and fabric cover that covers the sitting surface. The sitting surface is considered large enough for the whole body to be placed on it, and the pod, in addition to providing support like a tent, separates the person from the environment. This chair is inspired by the tents that were erected by desert tribes in Iran in the past. These tents were called "Taaj" in Persian.

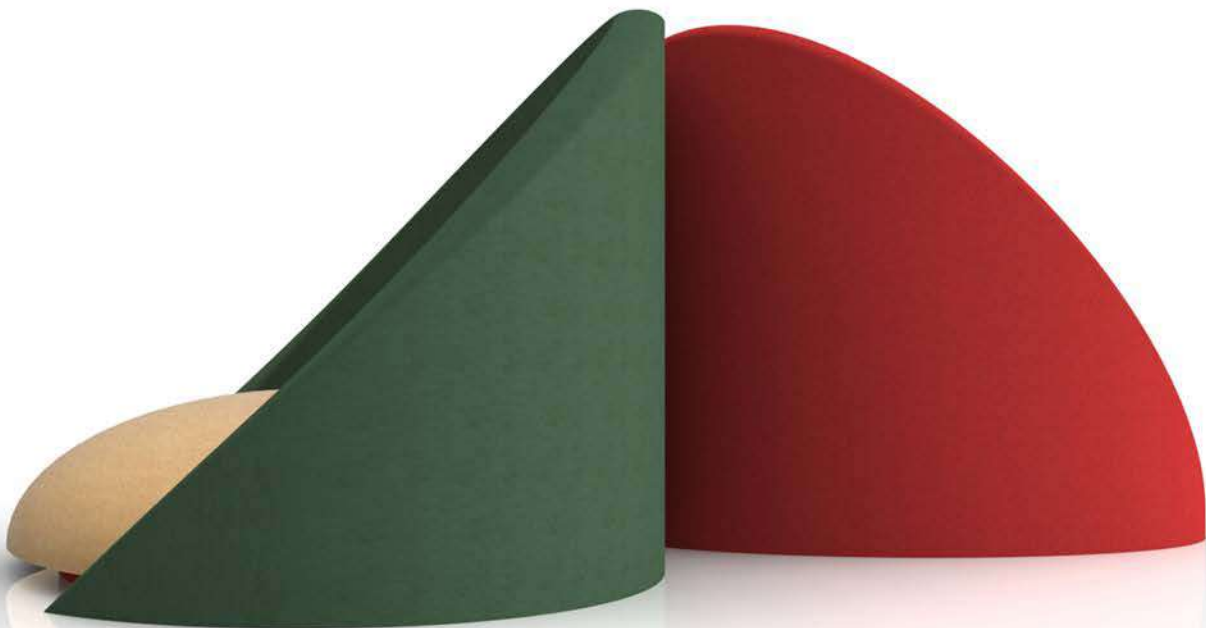
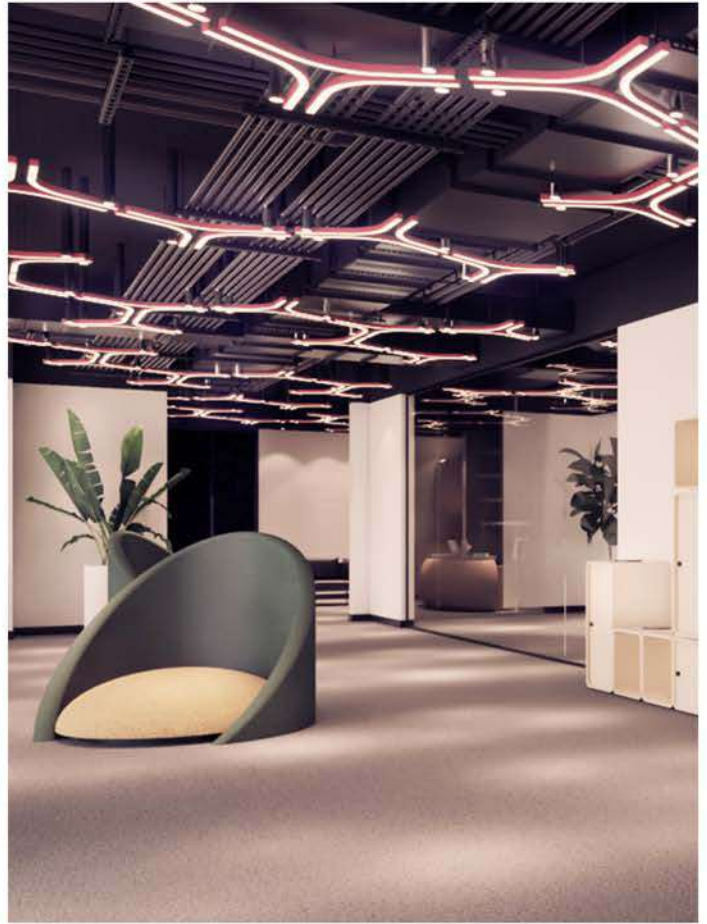



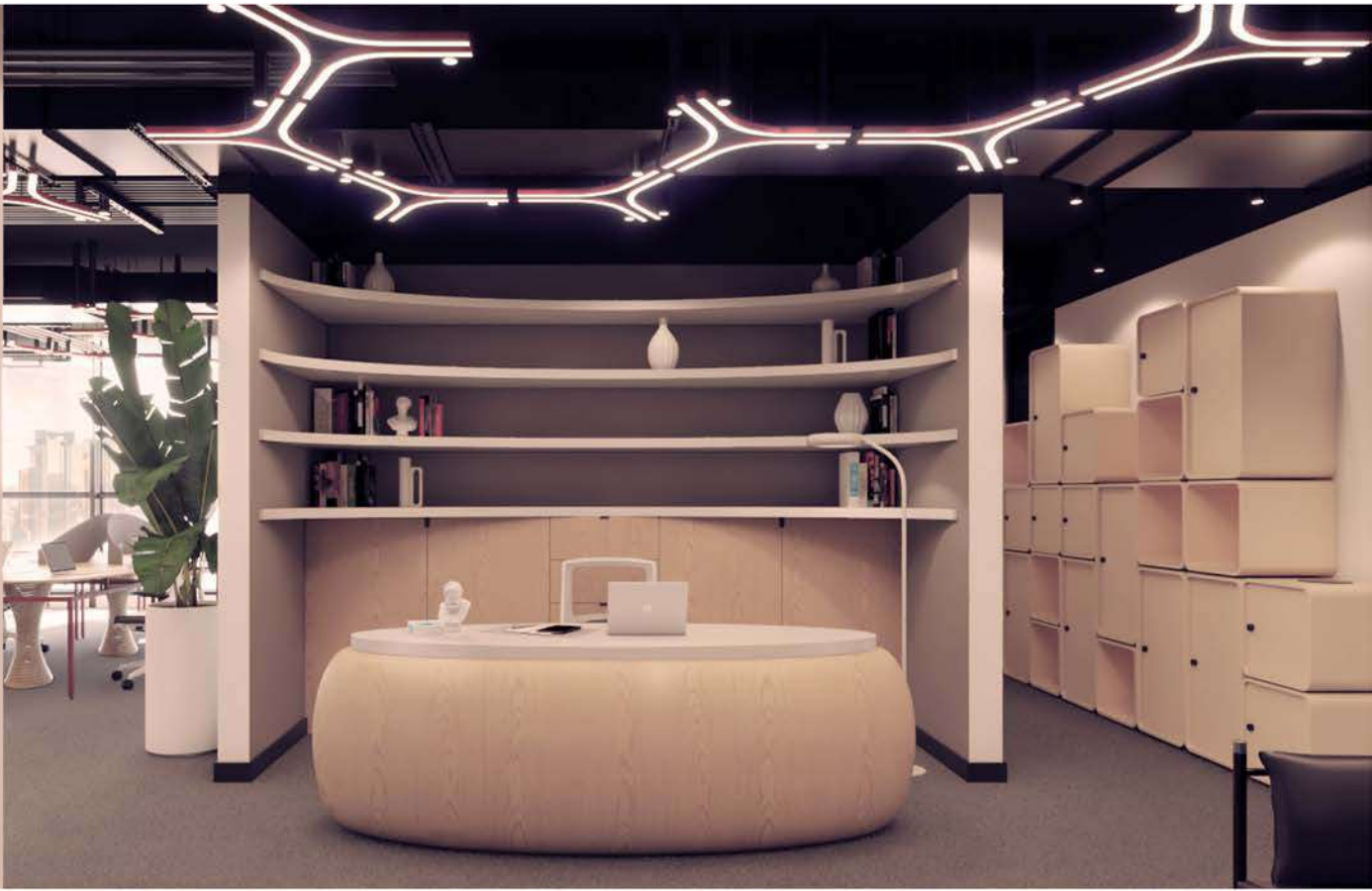

SANOFI COMPANY

This space belongs to a French business complex in Tehran. The client's request for the interior design of this office space was to use Iranian cultural motifs. The main idea for designing this space is inspired by the streets (Raaste) in the traditional Baazaars of Iran. The “Raaste” refers to a linear path that was the main backbone of the bazaar and on both sides of it there were shops and spaces for sales and commercial activities. The streets (Raaste) moved in the formal mass of the market and formed the access routes to different points, such as timchehs, shops, courtyards, mosques, and other spaces. In this plan, a north-south line is designed in the space, which organizes other work spaces around it as the main element. Arches are also a part of old Iranian architecture that evoke the atmosphere of the Baazaars. These arches are connected to the main pillars of the building and the electrical and mechanical installations are visibly placed among them. Partitions of colored glass are placed in some places to separate the spaces, which causes the eye to rotate in the space. These glasses are also inspired by traditional Iranian windows called "Owrsi".

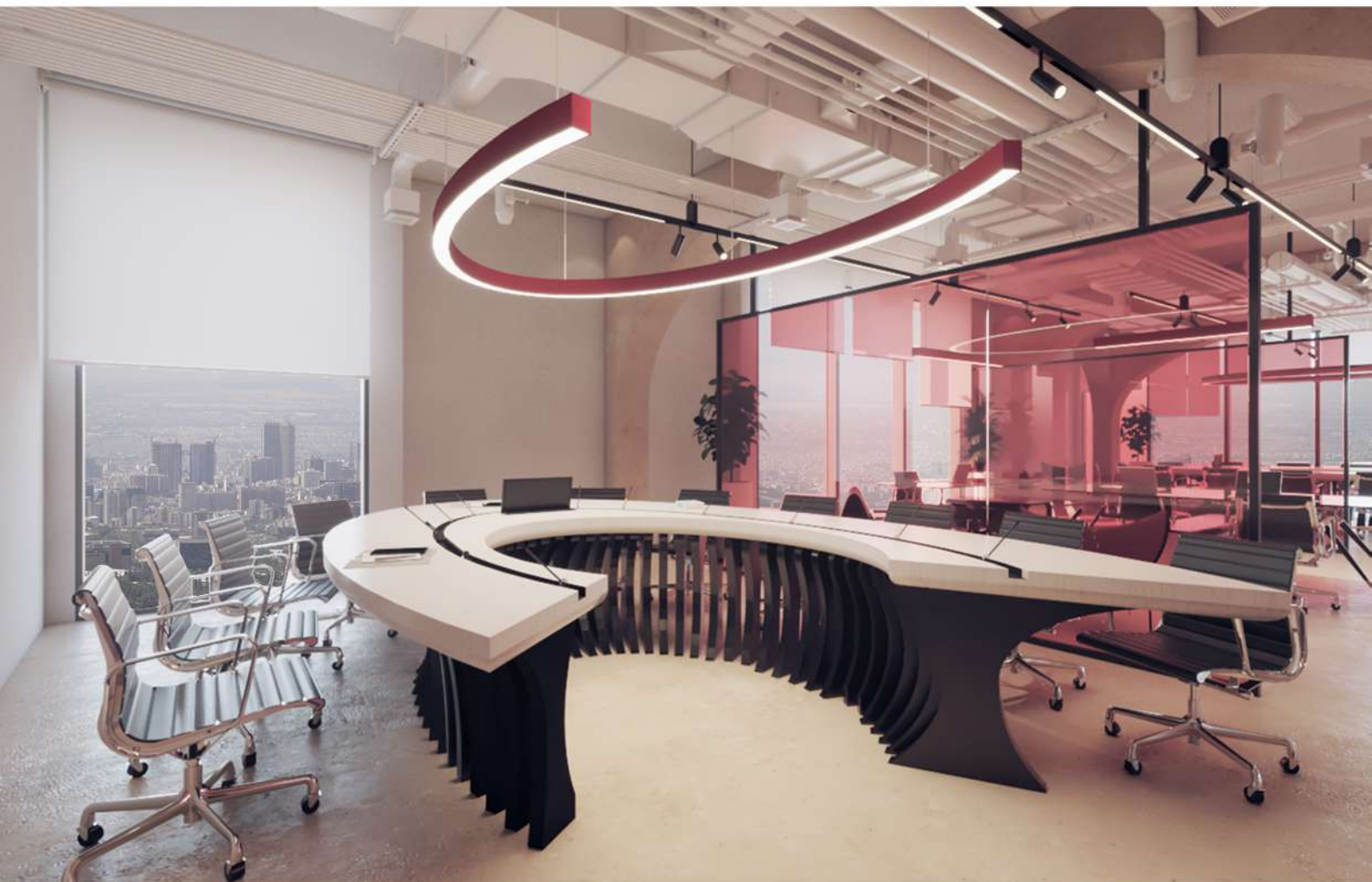

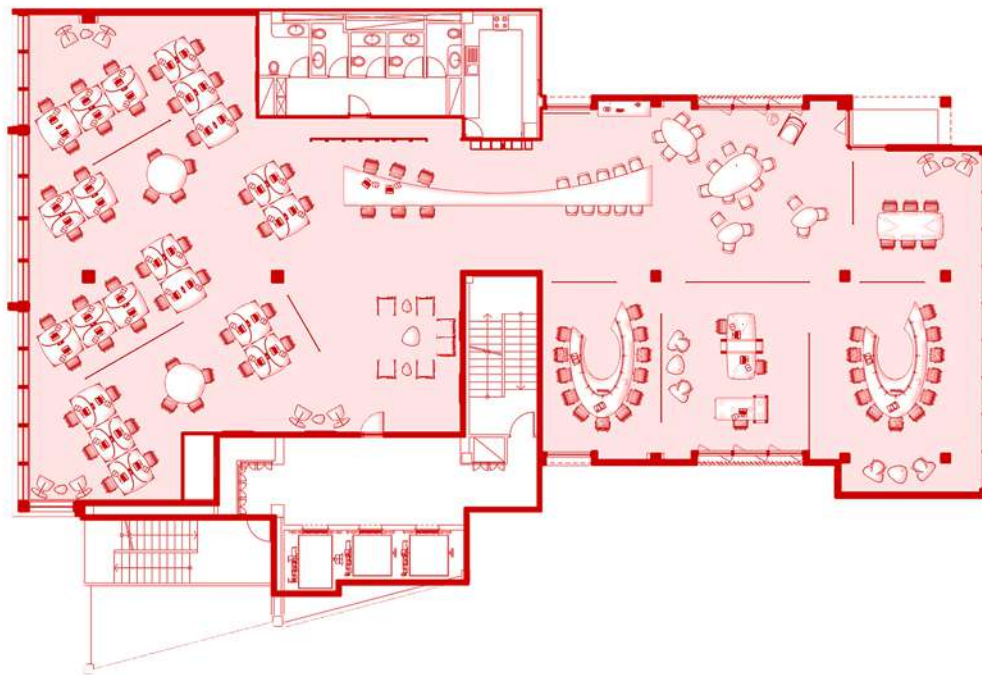
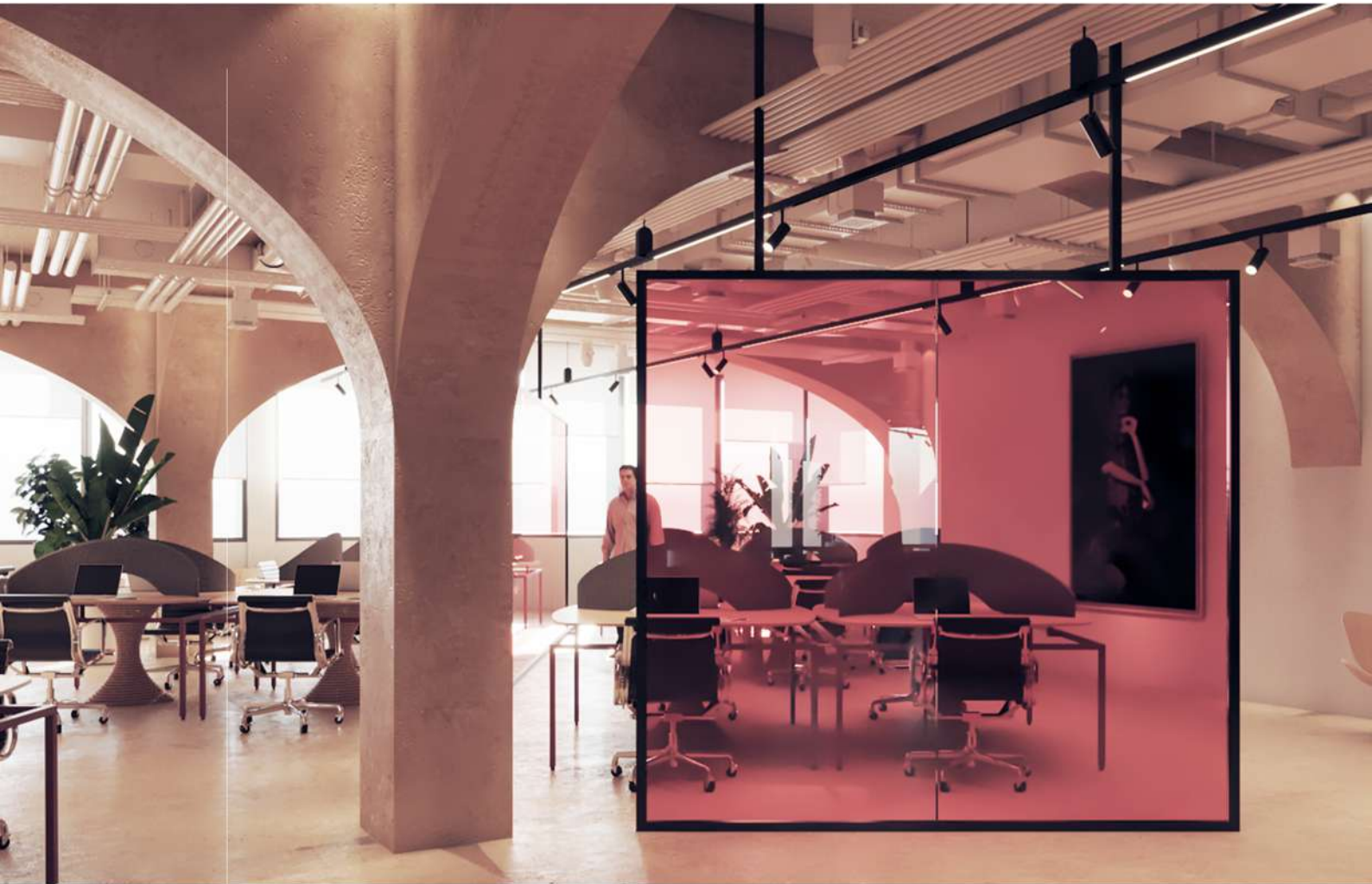





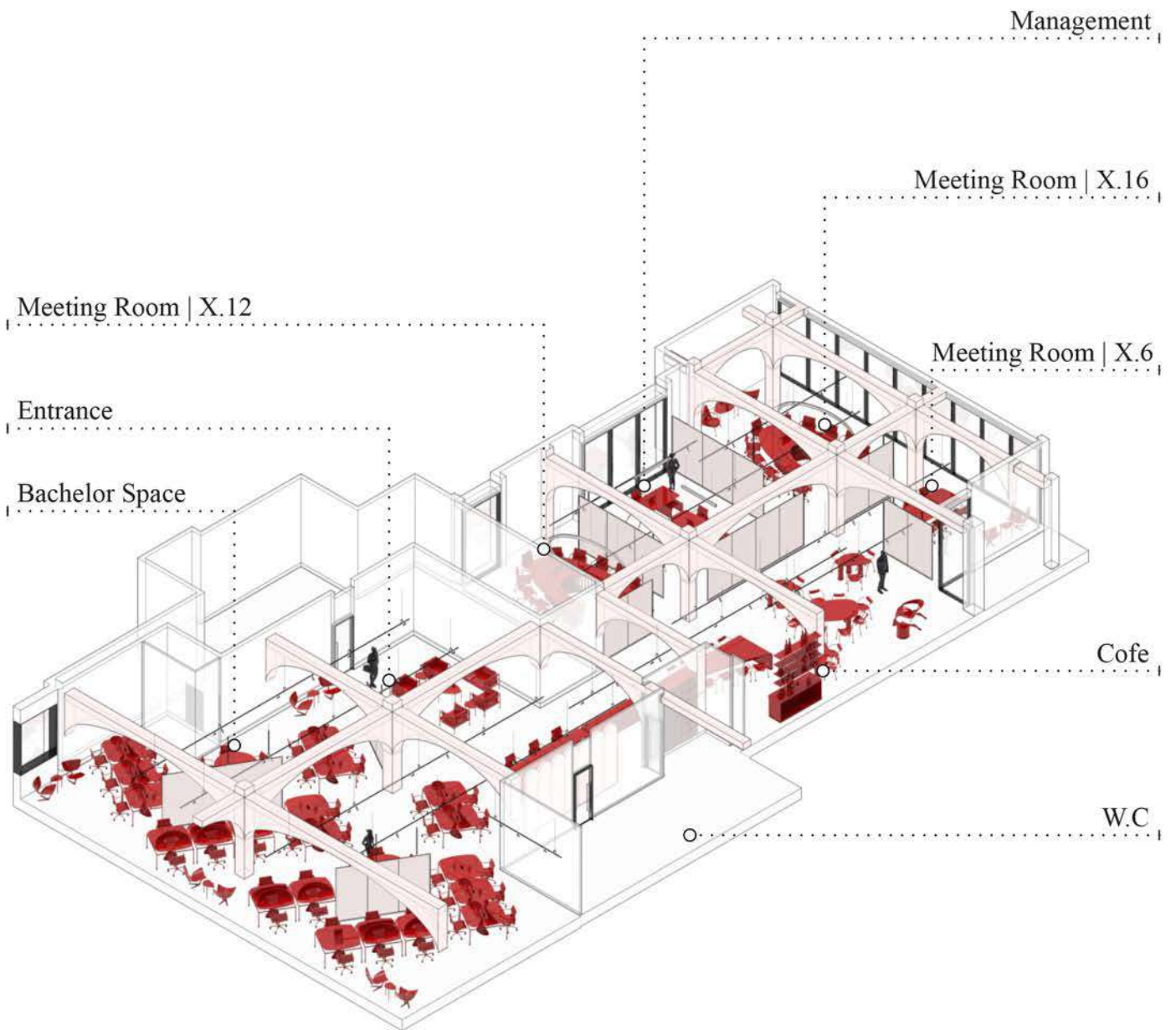

SEFID RESTAURANT

The design of this restaurant was an attempt to reimagine the dining spaces in the 30s and 40s in Iran, which were full of light, music, and noise, "lost" but "familiar" spaces where the youth of those decades used to experience a pure moment in it.

The designer's minimalist approach was an idea to compensate for the "censorship" in showing the past splendor of these spaces.

The initial space with the use of "office building parking" was on the basement, which had to provide the dining space for the users in the new function.

Achieving a "responsive" or in other words "functional" space has been the main goal of this project, but the designer moved the definition of "function" from just "eating" to "changing the atmosphere" and tried to improve the user's living experience. On the other hand, due to the limitations of the project in this sector (not only economic affairs but mostly cultural positions), he was forced to express his thoughts in a "concise" way.

The final goal was to create a "fun" space for the user, which was presented in the form of a "various" set of restrictions.

FUNCTION: Restaurant
CLIENT: Enerchimi Group
LOCATION: Tehran, Iran
CONDITION: Built
AREA: 250 m2
DATE: spring 2021







NITEL PARS LABORATORY

CLIENT: Nitel pars group

LOCATION: Shiraz Industrial town, Iran.

CONDITION: built

AREA: 450 m2

DATE: Fall 2022







OFFICE BUILDING NO. 102

-LOBBY -

This building had a very small entrance, but due to the change of function from residential to office, it was necessary to design and prepare this entrance for an office lobby. A pattern of black and white stone combination was designed for the floor in such a way that white lines moved in a black surface. This movement changed direction at some points and the lines intersected at some points. The pattern of the floor caused the eye to move in the space, which covered the smallness of the space. The pattern of the floor was placed on the ceiling again, and this time grooves were moving in a white surface. concentrated lights and linear lights were placed inside these grooves to provide general and local lighting for the space. In some parts of the walls, a pattern of carved mirrors was implemented to increase the visual expansion of the space due to the reflection.



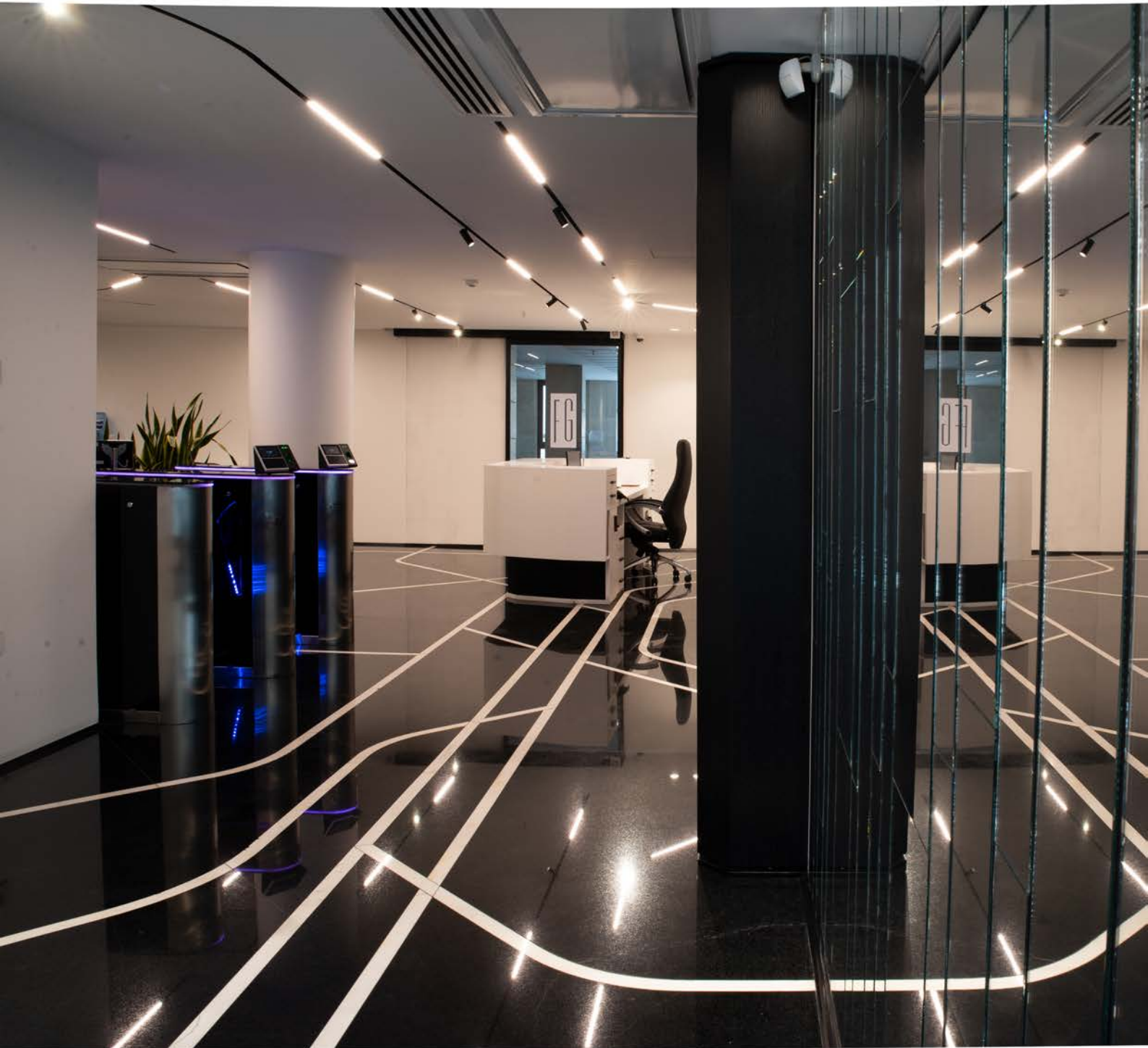

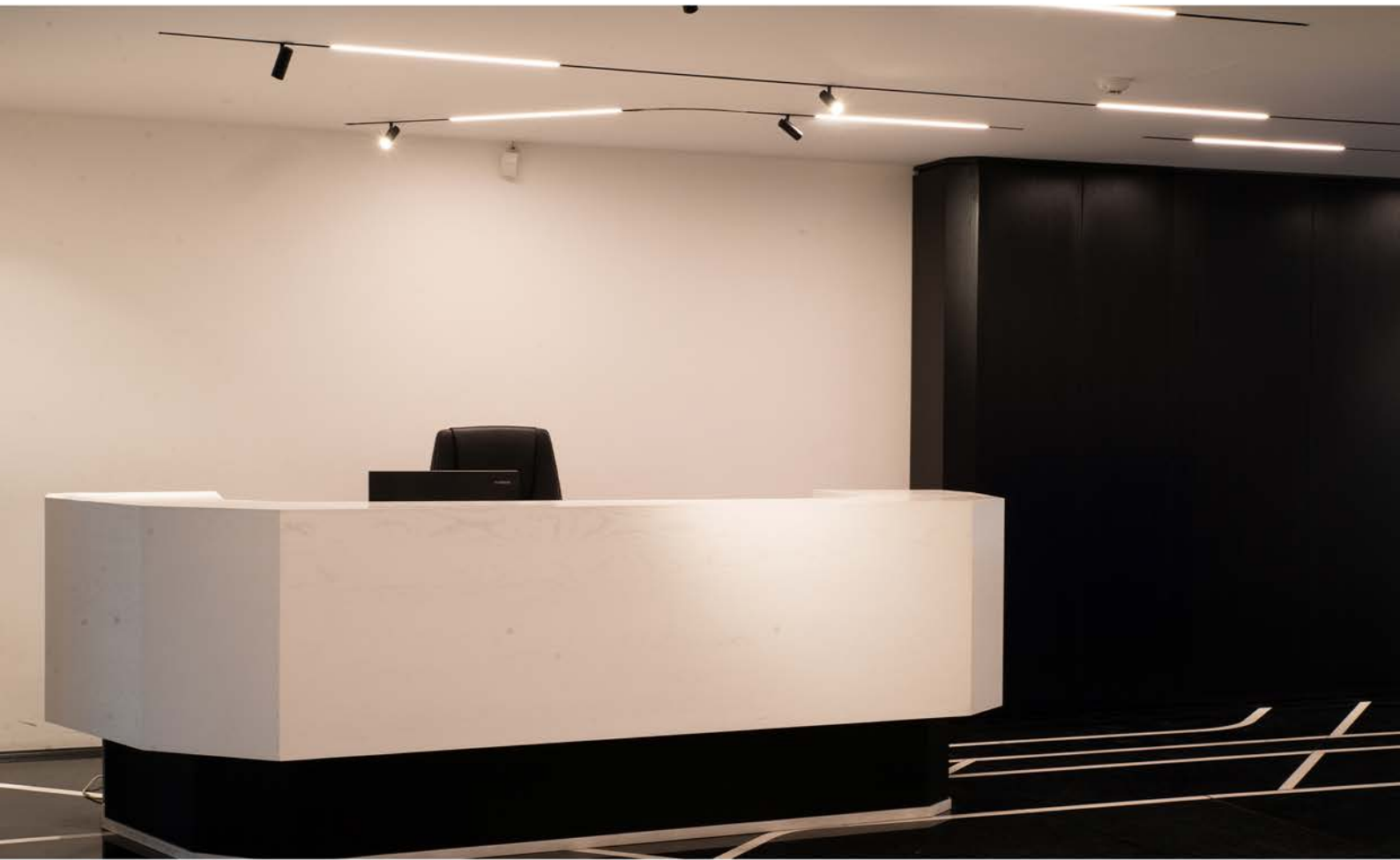



-WORKSPACE -

These workstations were designed for people who were supposed to be trained in this space first and then tested. Therefore, the workstations were designed in such a way that they have a suitable surface for doing work and provide privacy for people as private kiosks.



-WORKSPACE -

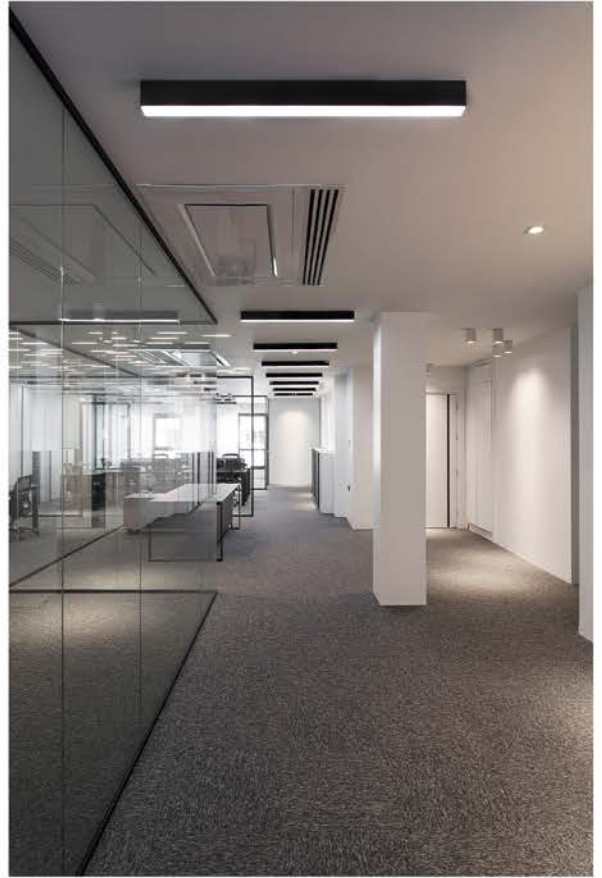

FUNCTION: Official
CLIENT: Arvinaj Group
LOCATION: Tehran, Iran
CONDITION: Built
FLOORS: 7
AREA: 1500 m2
DATE: Summer 2020







-MANAGEMENT AREA-







PHOENIX OFFICE BUILDING

-5TH FLOOR-

FUNCTION: Official
CLIENT: FGS Group
LOCATION: Tehran, Iran
CONDITION: Built
AREA: 474 m2
DATE: Fall 2019





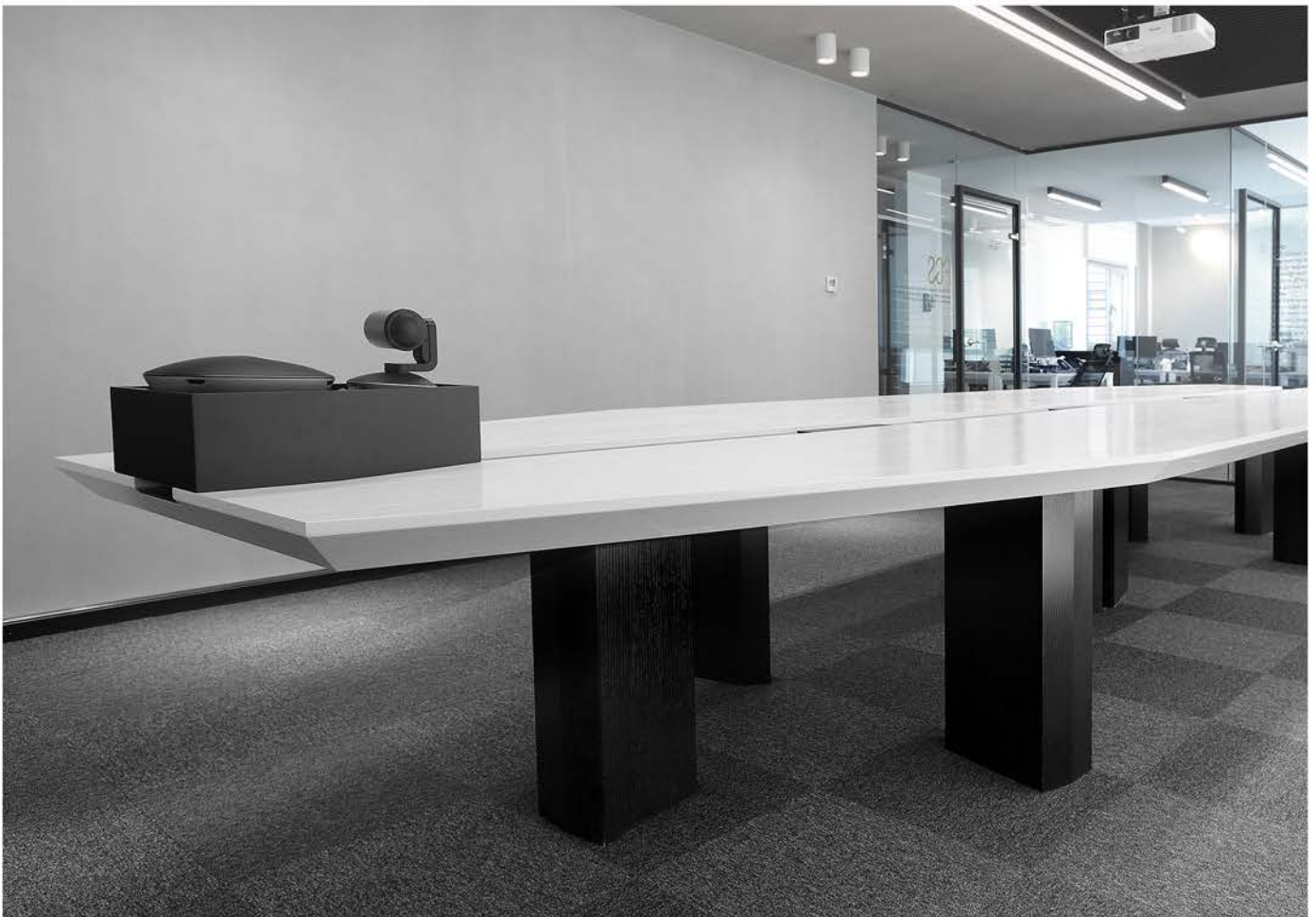

PHOENIX OFFICE BUILDING

-6TH FLOOR-



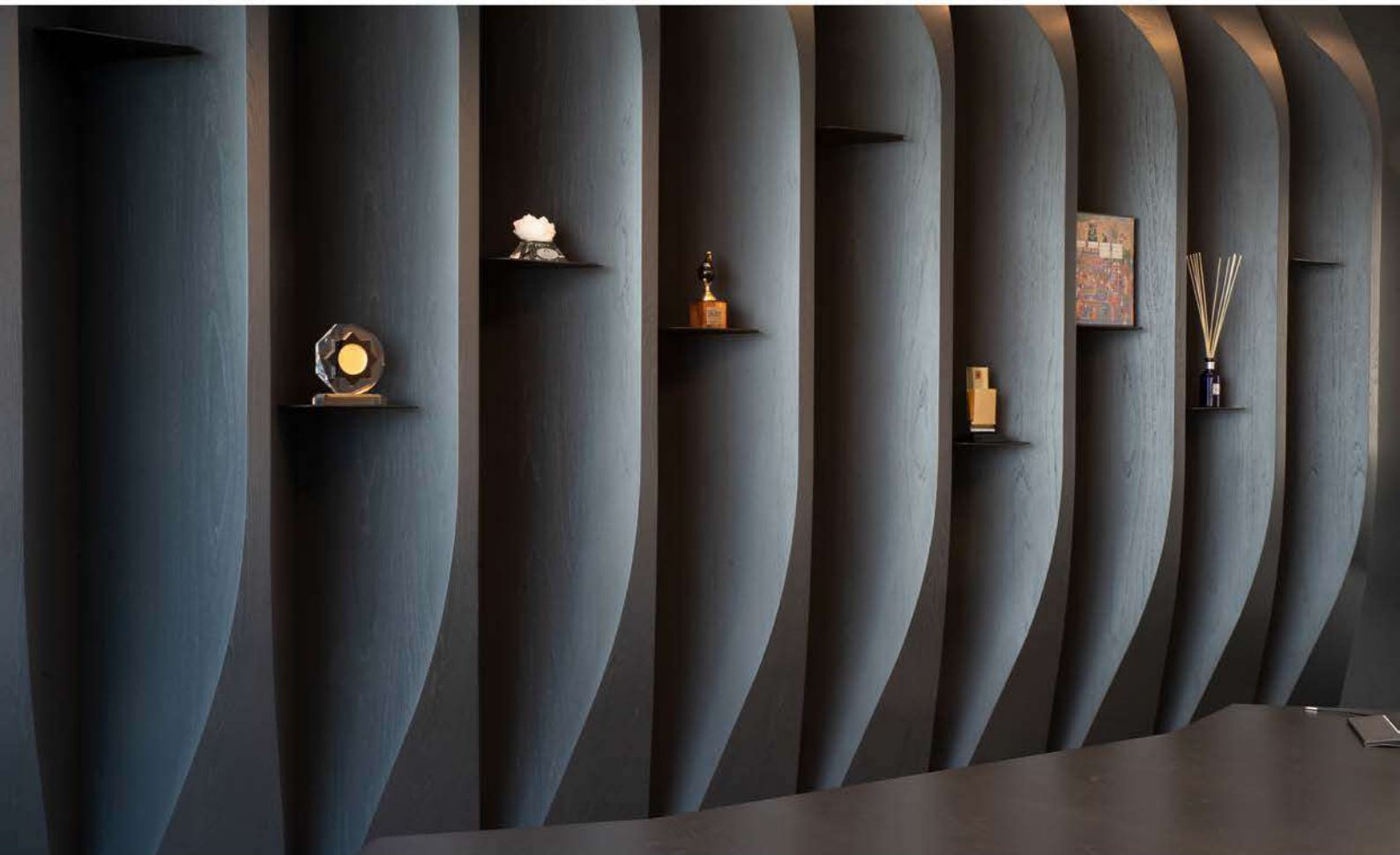









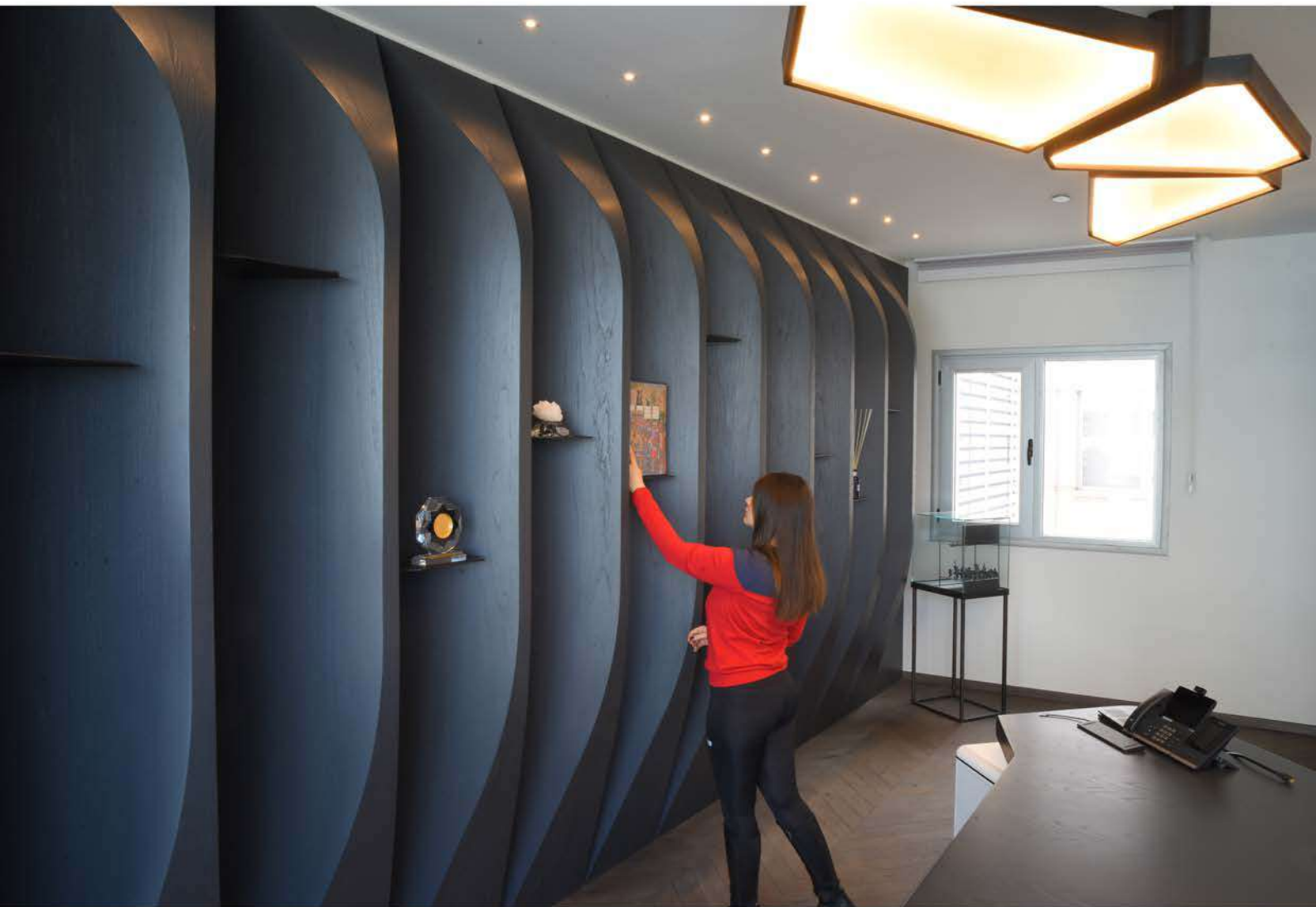

MAAHTAAB OFFICE BUILDING

FUNCTION: Official
CLIENT: FG Group
LOCATION: tehran, Iran
CONDITION: built
AREA: 1000 m2
FLOORS: 5
DATE: fall 2021



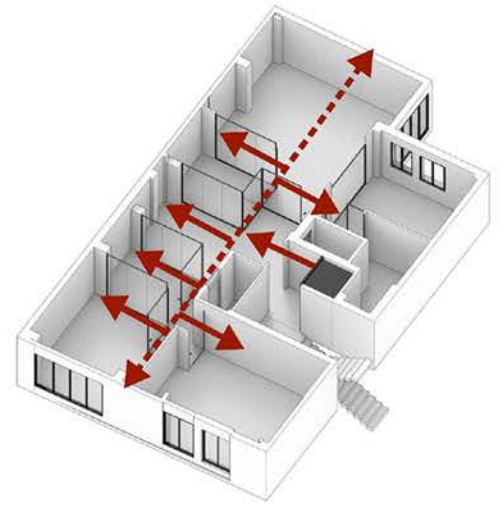
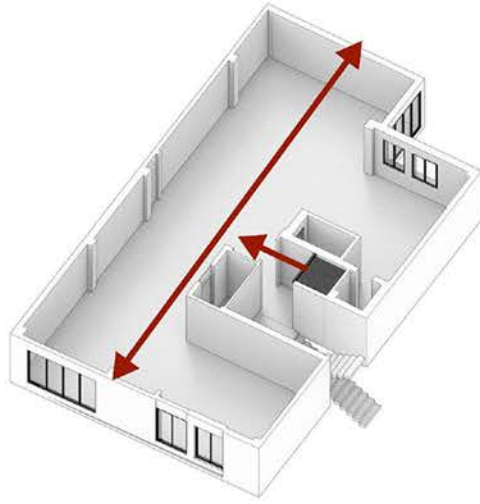
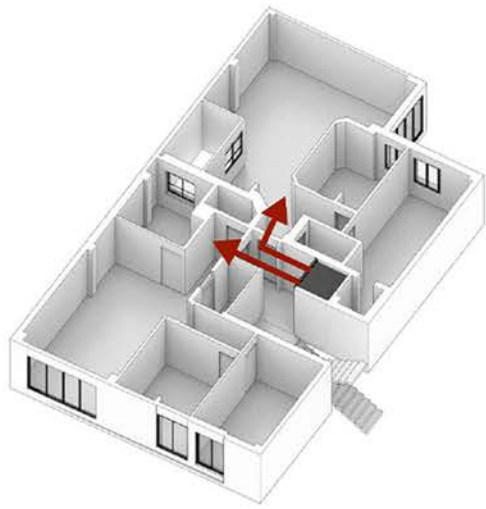

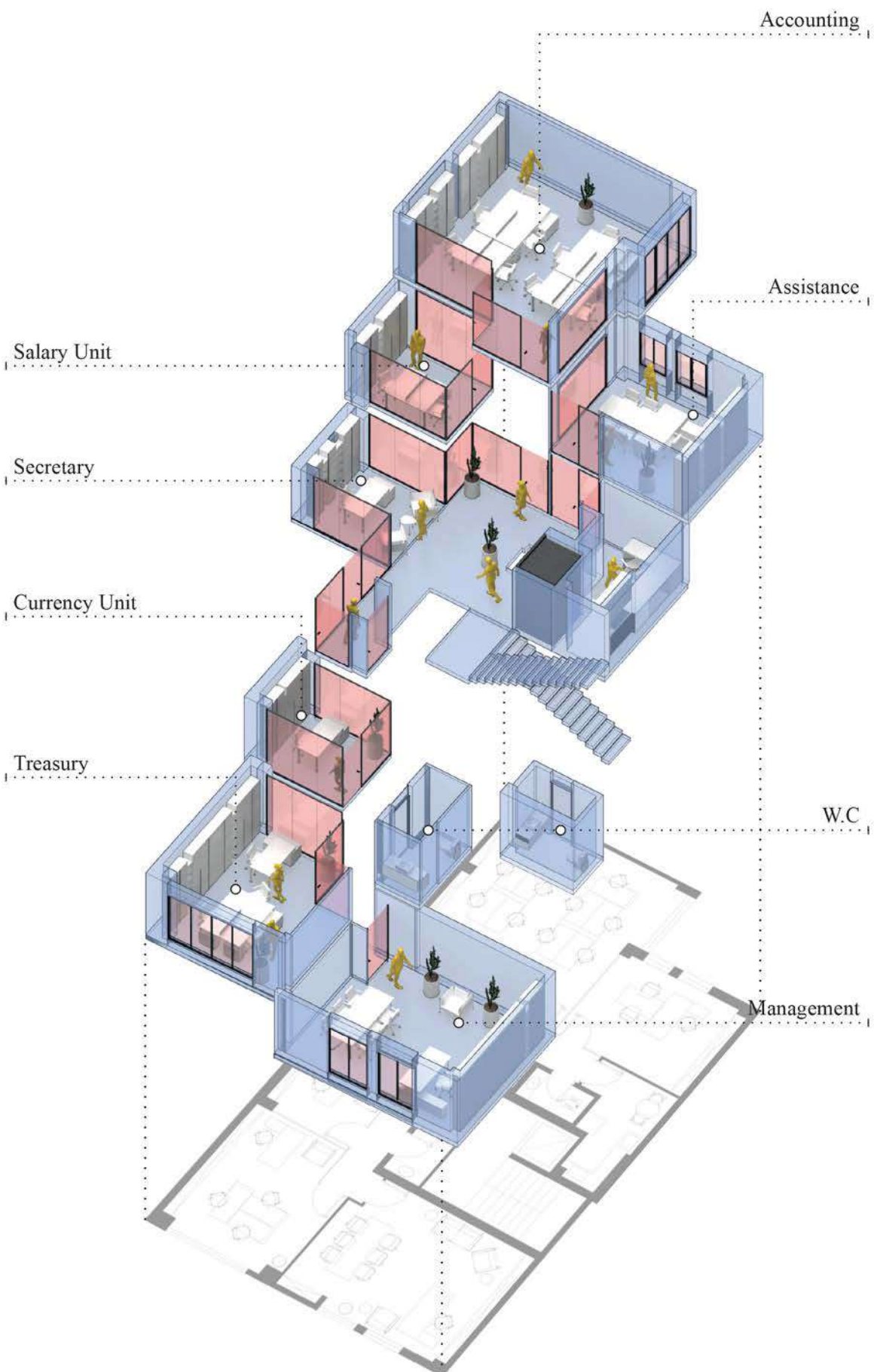

MAAHTAAB OFFICE BUILDING



FUNCTION: Official
CLIENT: FG Group
LOCATION: tehran, Iran
CONDITION: built
AREA: 1000 m2
FLOORS: 5
DATE: fall 2021







TARA MARKET



SUBJECT: Meeting Table Design
CLIENT: Arvinaj Group
LOCATION: bandar abbas, hormozgan, Iran
CONDITION: built
DATE: 2021





NIKOO LABORATORY

FUNCTION: Laboratory
CLIENT: Mr Aminian
LOCATION: Tehran, Iran
CONDITION: Concept Presented
AREA: 150 m²
DATE: Spring 2021

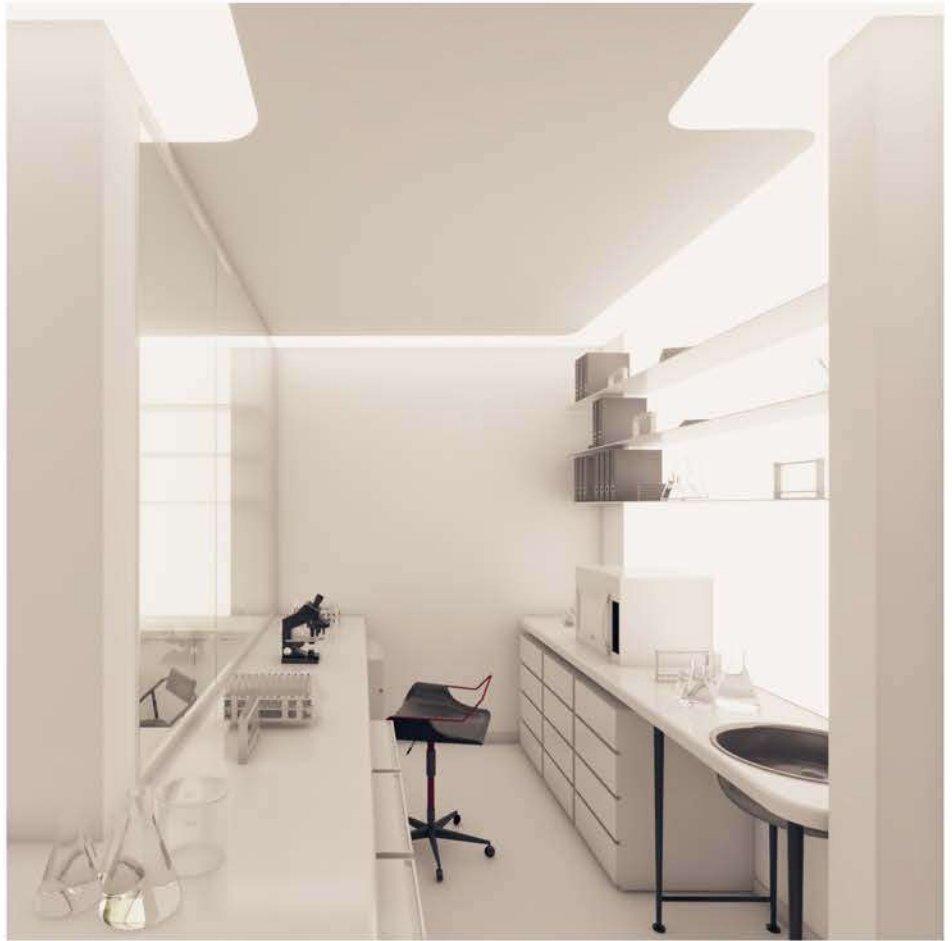



RAHYAFT CO.

FUNCTION: Official

CLIENT: Arvinaj Group

LOCATION: Pardis Technology Park, Tehran, Iran

CONDITION: Concept Presented For Furniture And Lighting

AREA: 1500 m²

DATE: Winter 2022



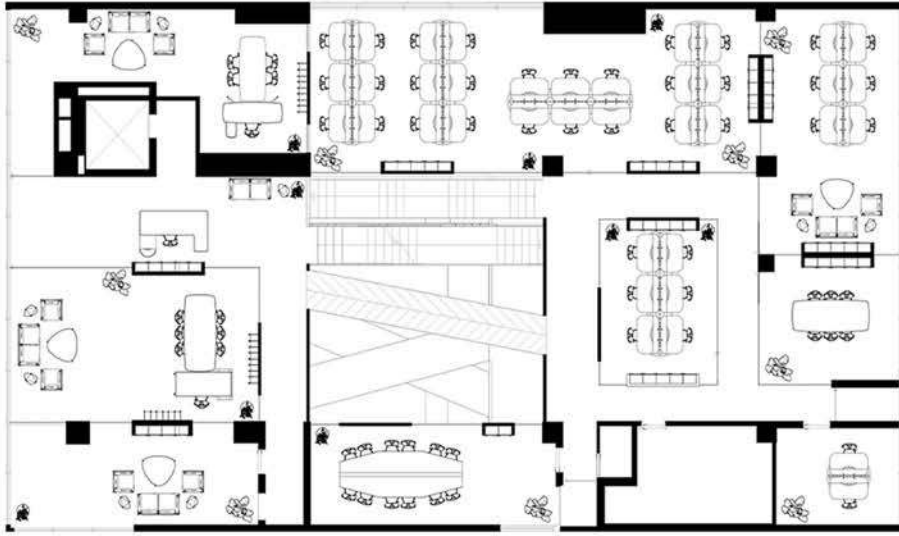



FOUMAN CHIMIE. CO

FUNCTION: Official
LOCATION: Tehran, Iran
CONDITION: Concept Presented
AREA: 170 m²
DATE: Summer 2021





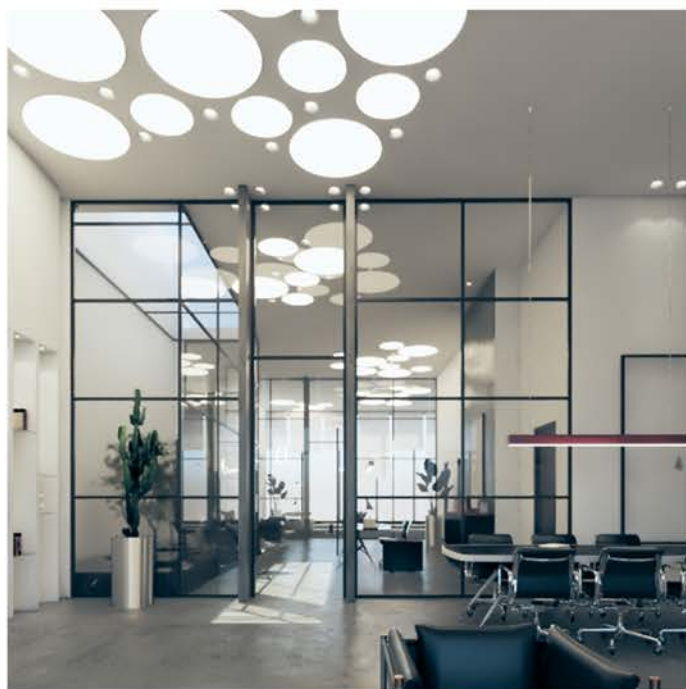





WHITE GYM

The subject of this project was to equip, prepare and transform an industrial shed into a space for sports activities. Because of the metal structure of the shed, there were many columns in the middle of the space. The repetition of these columns is used as the main feature of the space. A spindle-shaped form was designed for them, which was installed on the columns with a wooden structure. The high repetition of this form gave the space a rhythmic state.

In the next step, the Hexa lamp (this lamp was also designed by Hamoun Studio) was used for lighting. This light moved as a weave of light between the metal trusses and covered the air conditioning facilities.





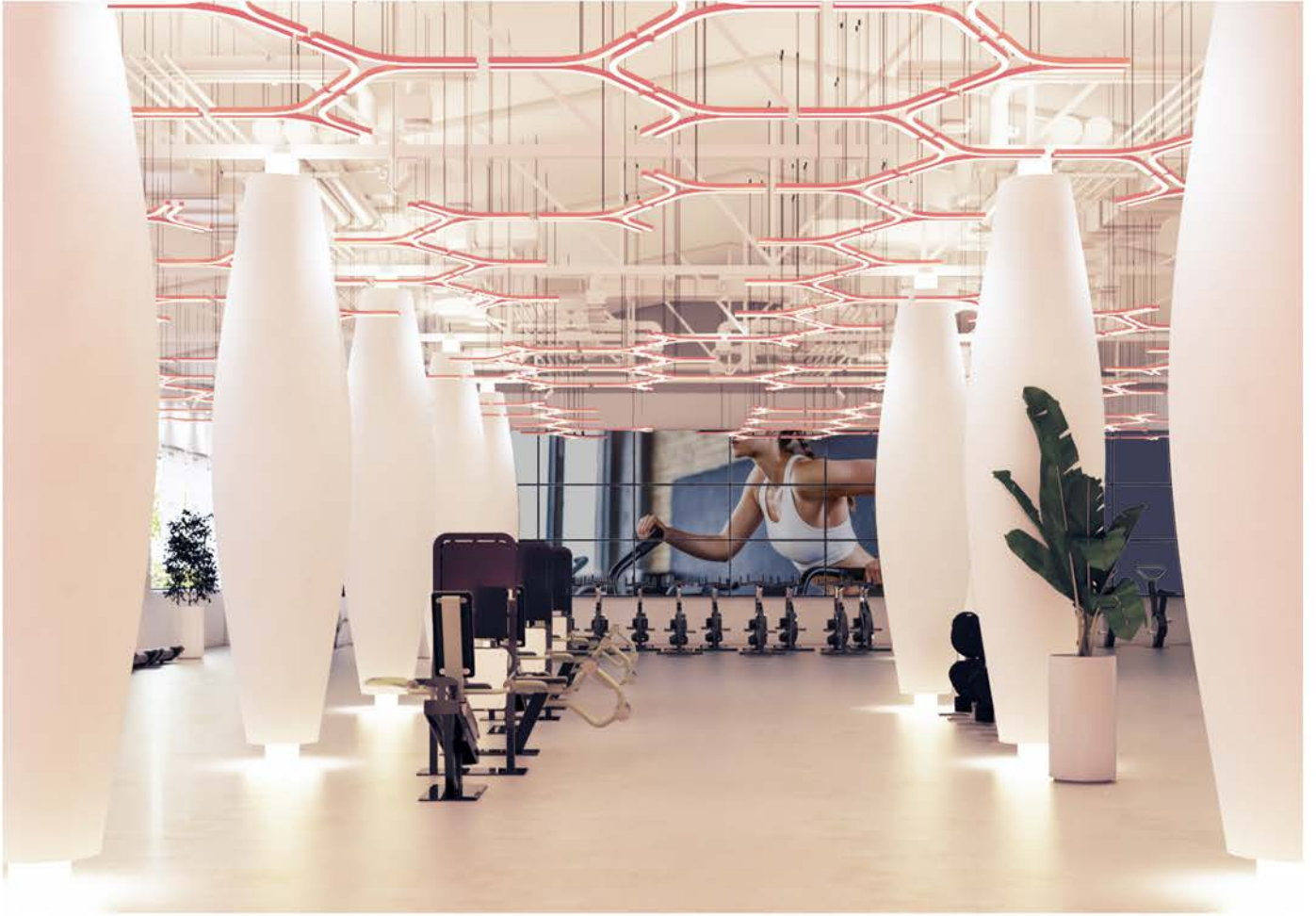

RONA LIGHTING GROUP OFFICE

FUNCTION: Official

LOCATION: Shiraz, Iran

CONDITION: Concept Presented

AREA: 130 m2

DATE: Fall 2022



ARIN COMPANY

FUNCTION: Official
CLIENT: Arin Group
LOCATION: Tenran, Iran
CONDITION: Built
AREA: 4000 m²
FLOORS: 9
DATE: Summer 2021

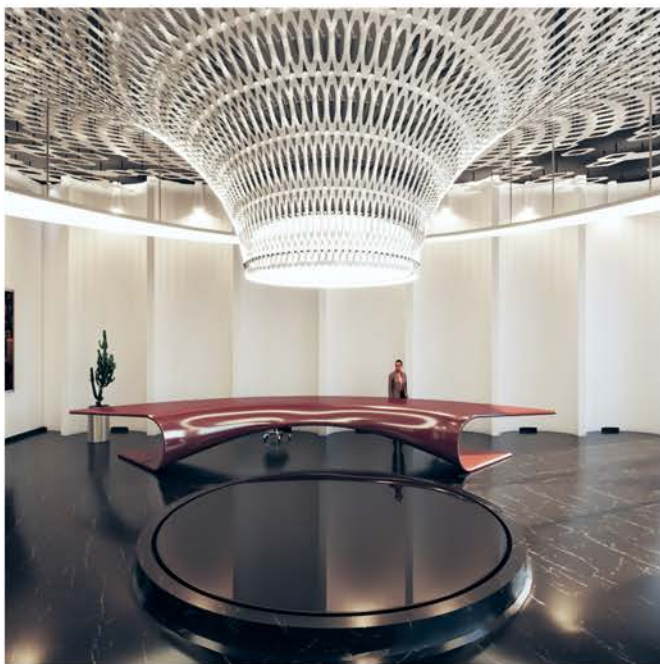





ISOMETRIC

ROOF GARDEN

BOARD OF DIRECTORS

FIDER

HOUSHMAND

ACADEMY

FINANCIAL

TAV

AC MANAGEMENT

CTS

PRICING

SALE

ROSHA

IT

HR

ADMIN

MEETING

LEGAL

CONTROLLING

TRADING

SEPAHRAN

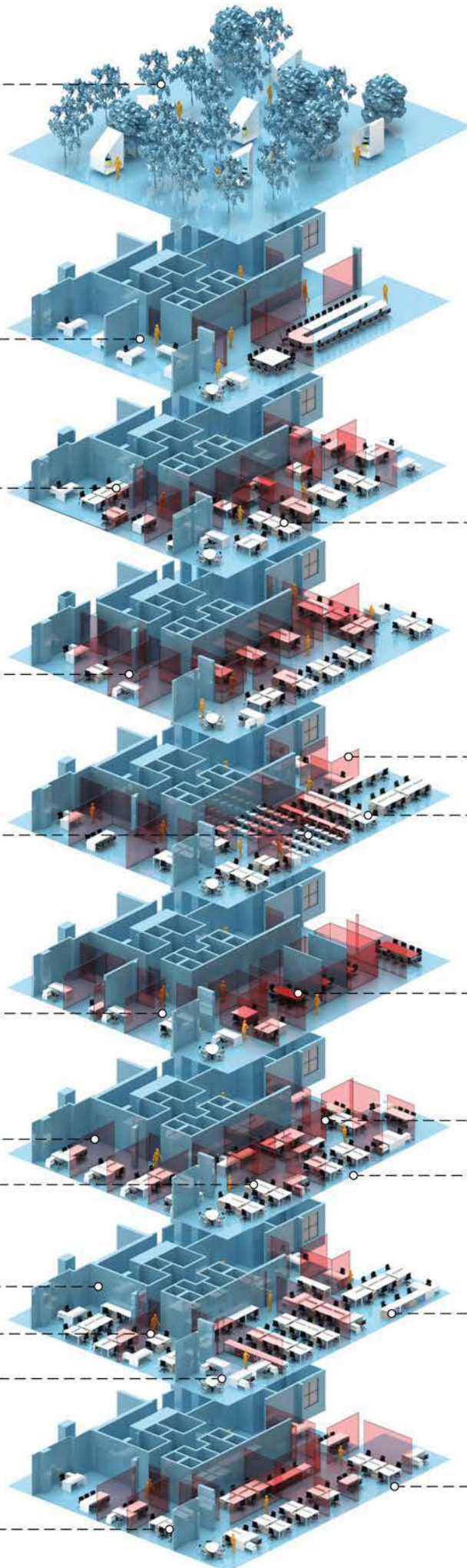



DIAGRAM PLAN

ROOF GARDEN

BOARD OF DIRECTORS

FIDER

HOUSHMAND

ACADEMY

HR

FINANCIAL

TAV

AC MANAGEMENT

CTS

PRICING

SALE

ROSHA

IT

ADMIN

MEETING

LEGAL

CONTROLLING

TRADING

SEPAHRAN

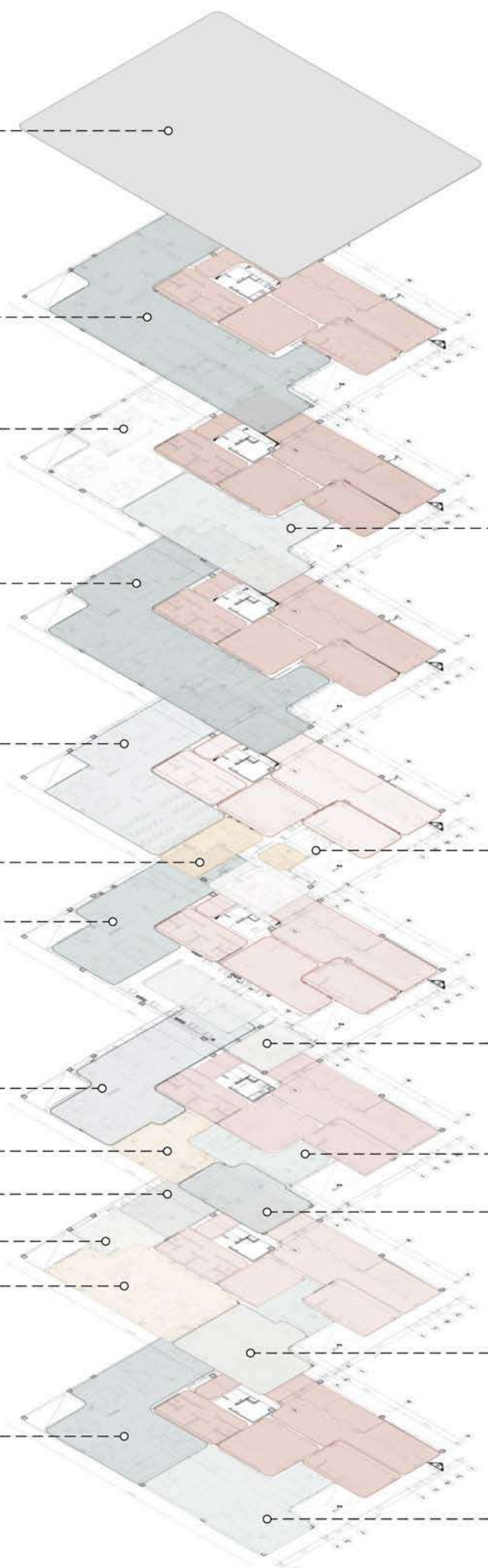





802 ADMINISTRATIVE UNIT

FUNCTION: Official

CLIENT: Rona Group

LOCATION: Tehran, Iran

CONDITION: Concept Presented

AREA: 150 m²

DATE: Summer 2021



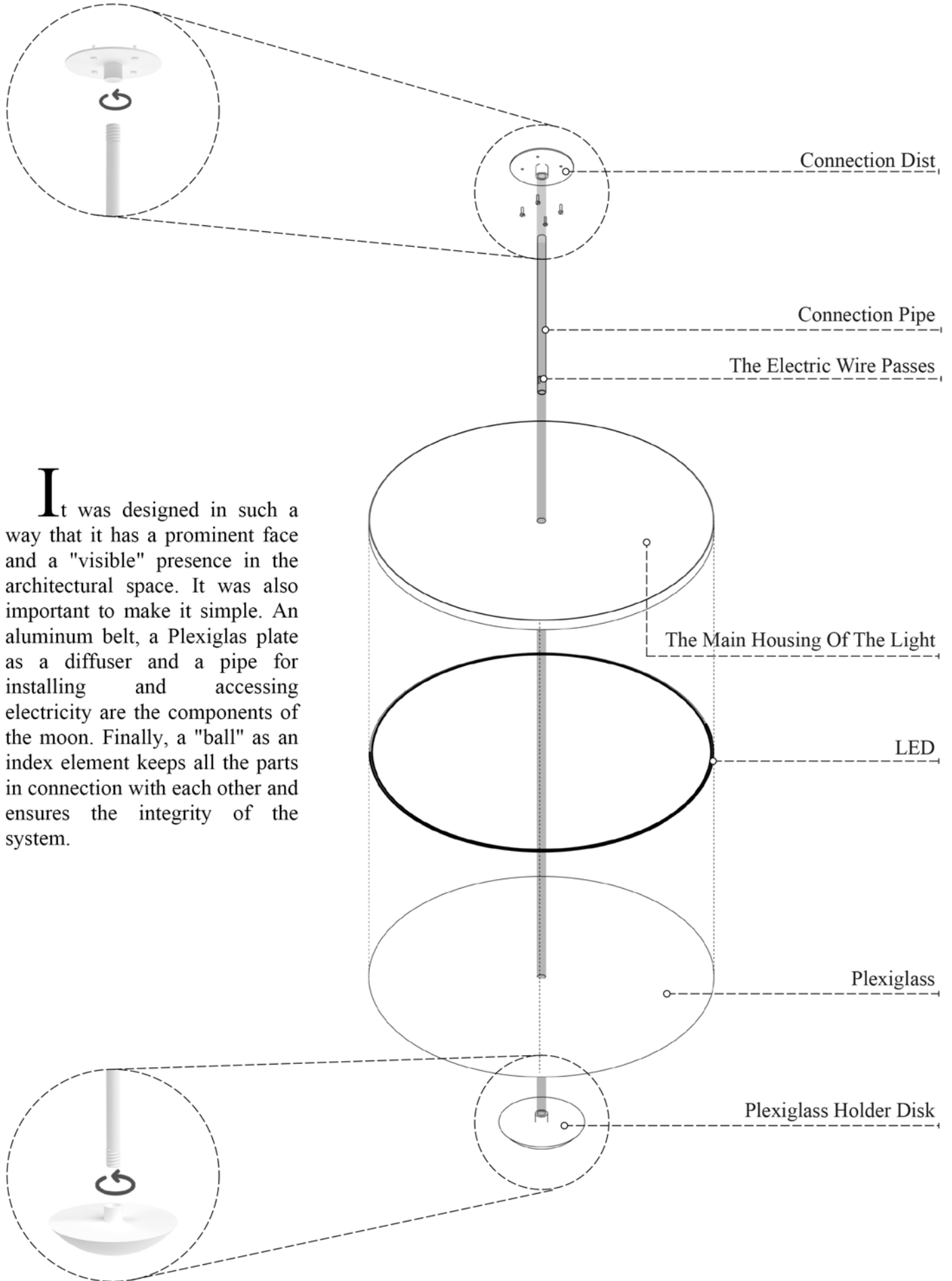

It was designed in such a way that it has a prominent face and a "visible" presence in the architectural space. It was also important to make it simple. An aluminum belt, a Plexiglas plate as a diffuser and a pipe for installing and accessing electricity are the components of the moon. Finally, a "ball" as an index element keeps all the parts in connection with each other and ensures the integrity of the system.

AFTAB OFFICE BUILDING

FUNCTION: Official
CLIENT: Fateh Group
LOCATION: Tehran, Iran
CONDITION: Under Construction
AREA: 1300 m²
FLOORS: 5
DATE: 2020





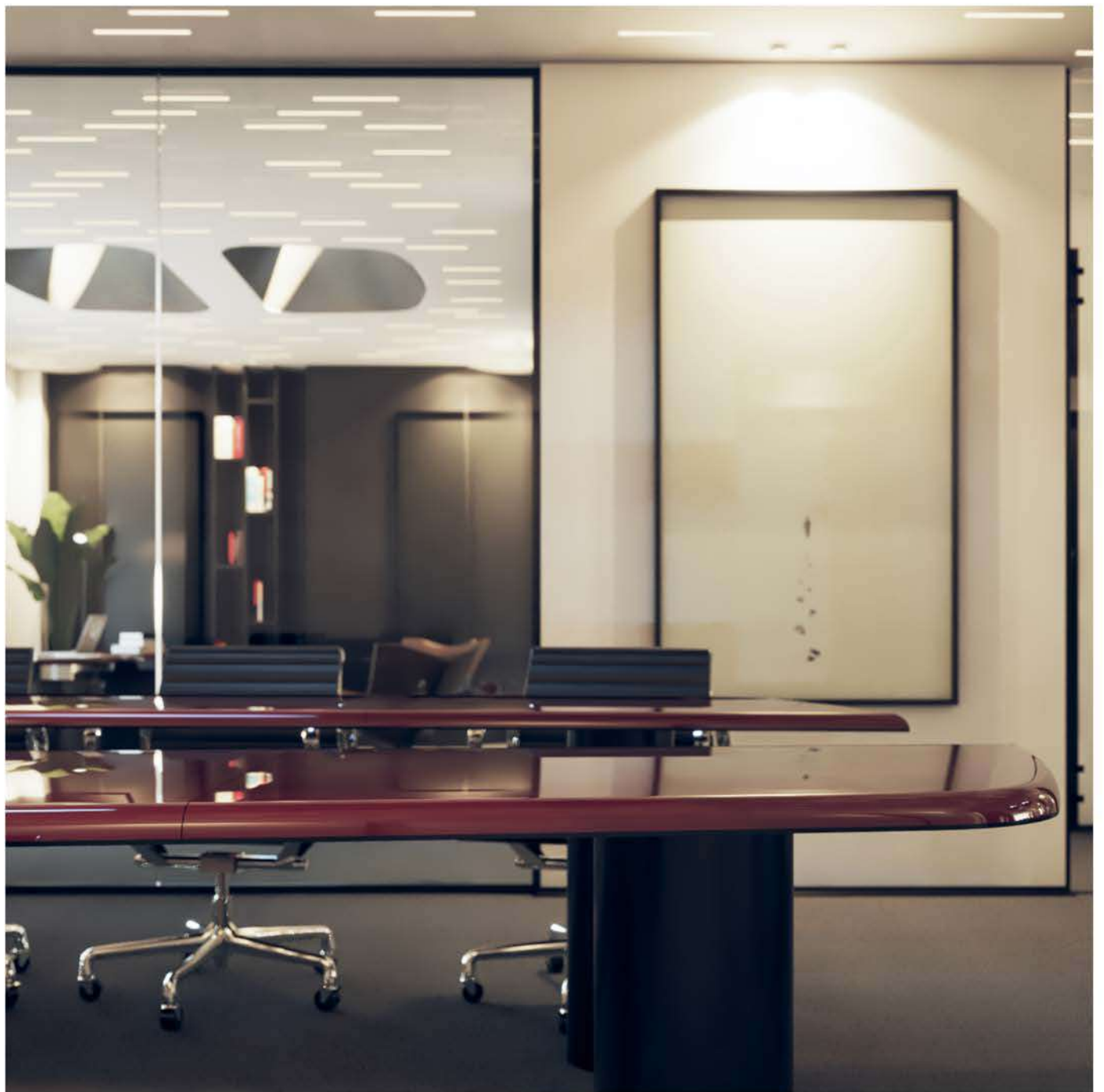





Arvinaj